



SPI NAND FLASH

Datasheet

Future routine revisions will occur when appropriate, without notice. Contact XTX TECHNOLOGY LIMITED, sales office to obtain the latest specifications and before placing your product order. Please also pay attention to information published by XTX TECHNOLOGY LIMITED by various means, including XTX TECHNOLOGY LIMITED. Home page (<http://www.xtxtech.com>); Technical Contact: fae@xtxtech.com

Trademarks

XTX TECHNOLOGY LIMITED name and logo, the XTX logo are trademarks or registered trademarks of XTX TECHNOLOGY LIMITED or its subsidiaries in China. XTX TECHNOLOGY LIMITED, Printed in the China, All Rights Reserved.

Serial NAND Flash Memory

3.0V 2 Gigabits Multi I/O with built in internal ECC

Overview

The XT26G02A is a 2G-bit (256M-byte) SPI (Serial Peripheral Interface) NAND Flash memory, with advanced write protection mechanisms. The XT26G02A supports the standard Serial Peripheral Interface (SPI), Dual/Quad I/O option.

- **2 Gbit of NAND Flash memory**
 - Single-level cell (SLC) technology
 - Page size : 2112 bytes(2048 + 64 bytes)
 - Block size : 64 pages(128K + 4K bytes)
 - Device size: 2Gb(2048 blocks)
- **Serial Interface**
 - Standard SPI: CLK, CS#, DI, DO, WP#, HOLD
 - Dual SPI: CLK, CS#, DQ0, DQ1, WP#, HOLD#
 - Quad SPI: CLK, CS#, DQ0, DQ1, DQ2, DQ3
- **High Performance**
 - 90MHz for fast read with 30PF load
 - Quad I/O data transfer up to 350Mbit/s
 - 2112/2048/64/16 word read option
 - 2K-Byte cache for fast random read
 - Cache read and cache program
- **Advanced Security Features**
 - Write protect all/portion of memory via software
 - Available 8K-Byte OTP region
- **Program/Erase/Read Speed**
 - Page Program time : 350us typical (with ECC)
 - BLOCK ERASE time : 3ms typical
 - PAGE READ time : 260us typical (with ECC)
- **Single Supply Voltage : 2.7V~3.6V**
- **Advanced Security Features**
 - Internal ECC option, per 528 bytes
 - Internal data move by page with ECC
 - Promised golden block0
- **Package**
 - 8-pin WSON (8*6mm)
 - 24-Ball TFBGA (8*6mm)
 - All Packages are RoHS Compliant and Halogen-free
- **Data retention: 10 years(Typ)**

CONTENTS

1. PACKAGING TYPE AND PIN CONFIGURATIONS	3
2. BLOCK DIAGRAM	4
3. MEMORY MAPPING	5
4. ARRAY ORGANIZATION	6
5. DEVICE OPERATION	7
6.1. SPI MODES.....	7
6.2. PIN FUNCTION DESCRIPTION.....	8
6.3. COMMAND SET TABLES	10
6.4. WRITE OPERATIONS.....	11
6.5. FEATURE OPERATIONS	12
6.6. READ OPERATIONS.....	13
6.6.1. Page Read	13
6.6.2. Page Read to Cache (13H)	13
6.7. PROGRAM OPERATIONS	19
6.7.1. Page Program.....	19
6.7.2. Program Load (PL) (02H)	20
6.7.3. Program Load x4 (PL x4) (32H)	20
6.7.4. Program Execute (PE) (10H)	21
6.7.5. Internal Data Move	22
6.7.6. Program Load Random Data (84H).....	22
6.7.7. Program Random Data x4 (C4H/34H).....	23
6.7.8. Program Random Quad IO (72H).....	23
6.8. ERASE OPERATIONS.....	24
6.9. RESET OPERATION	25
6.10. WRITE PROTECTION.....	25
7. STATUS REGISTER	27
8. OTP REGION	28
OTP Access.....	28
OTP Protect.....	28
9. ERROR MANAGEMENT	29
10. ECC PROTECTION	30
11. ELECTRICAL CHARACTERISTICS	31
11.1. ABSOLUTE MAXIMUM RATINGS.....	31
11.2. PIN CAPACITANCE	31
11.3. POWER-UP AND POWER-DOWN TIMINGS	31
11.4. DC ELECTRICAL CHARACTERISTICS	33
11.5. AC MEASUREMENT CONDITIONS.....	33
11.6. AC ELECTRICAL CHARACTERISTICS.....	34
12. SPI SERIAL TIMING	35
13. ORDERING INFORMATION	36
14. PACKAGE INFORMATION	37
14.1. 8-PAD WSON8 (8*6MM).....	37
14.2. 24-BALL TFBGA (8*6MM).....	38
15. REVISION HISTORY	39

1. Packaging Type and Pin Configurations

XT26G02A offered in WSON8 (8x6mm) and BGA24 (8x6mm) packages as shown in Figure 1 and Figure 2, respectively. Package diagrams and dimensions are illustrated at the end of this datasheet.

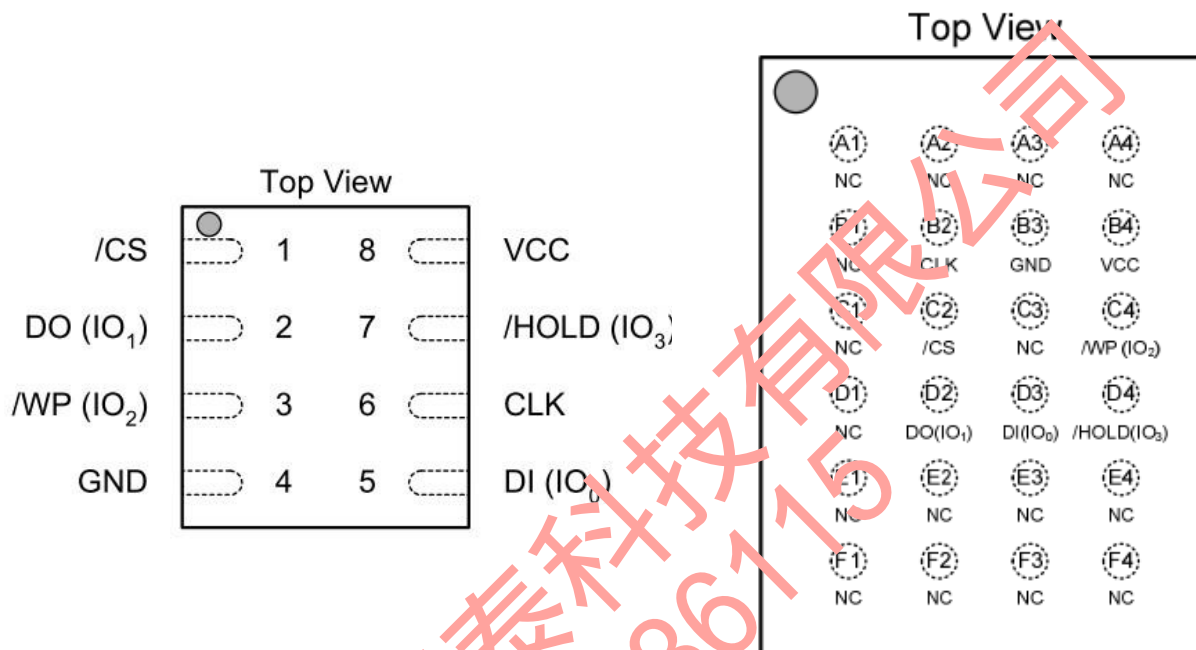

PIN Assignment & Description

PIN NO.	PIN NAME	I/O	FUNCTION
1	CS#	I	Chip Select Input
2	DO (DQ ₁)	I/O	Data Output (Data Input Output 1) ⁽¹⁾
3	WP# (DQ ₂)	I/O	Write Protect Input (Data Input Output 2) ⁽²⁾
4	VSS		Ground
5	DI (DQ ₀)	I/O	Data Input (Data Input Output 0) ⁽¹⁾
6	CLK	I	Serial Clock Input
7	HOLD# (DQ ₃)	I/O	Hold Input (Data Input Output 3) ⁽²⁾
8	VCC		Power Supply

Note:

- 1 DQ₀ and DQ₁ are used for Dual SPI instructions.
- 2 DQ₀ – DQ₃ are used for Quad SPI/DDR instructions

2. Block Diagram

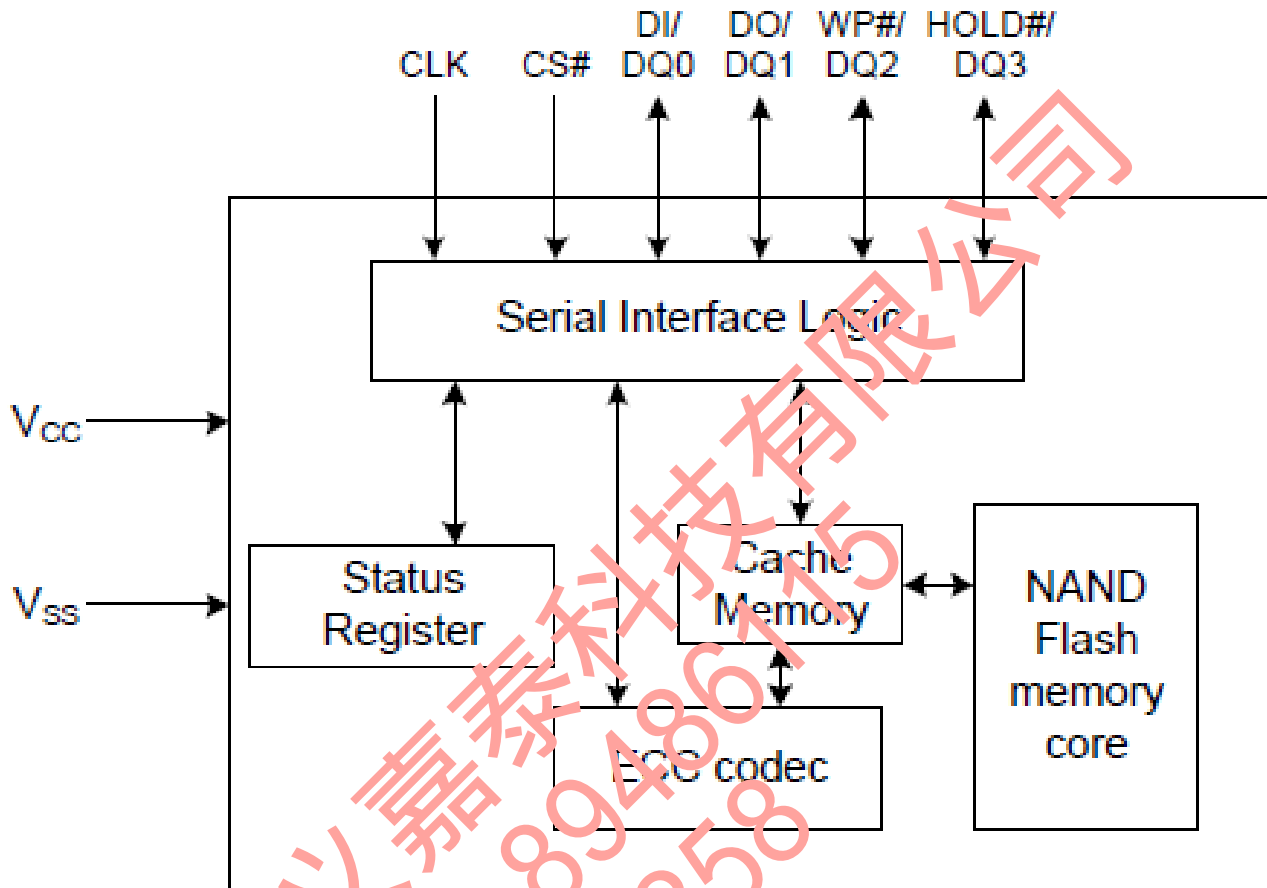

3. Memory Mapping

Figure 3 Memory Map

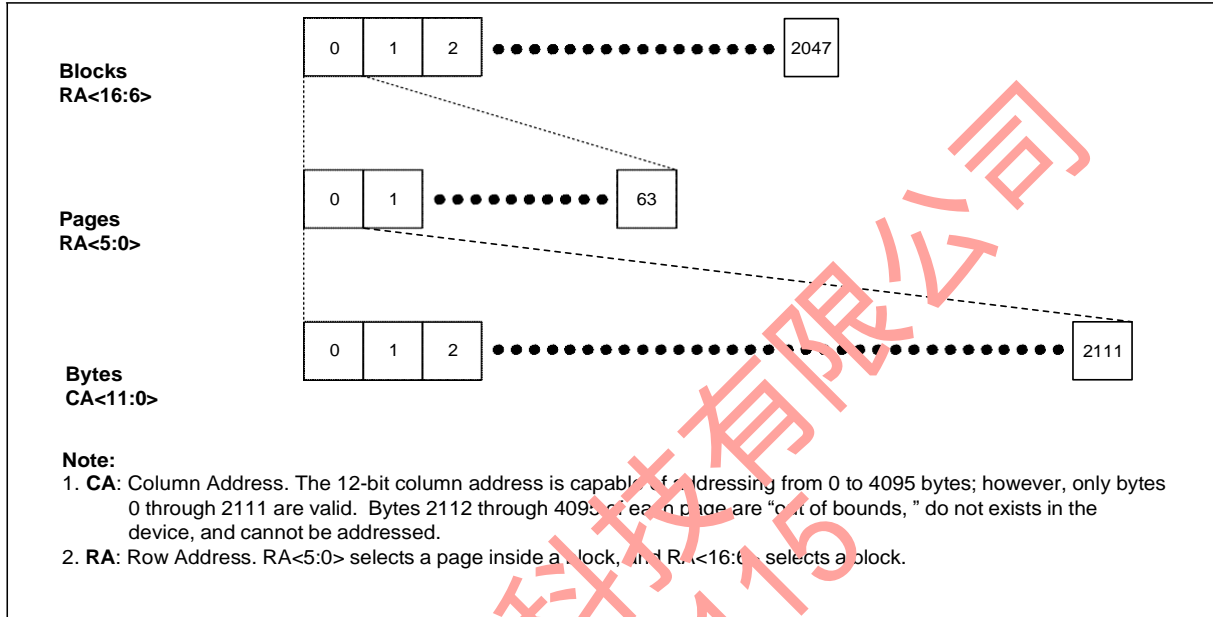

深圳市义嘉泰科技有限公司
 TEL: 0755-89486115
 QQ: 2637667358

4. Array Organization

Table 2 Array Organization

Each device has	Each block has	Each page has	Unit
256M + 8M	128K + 4K	2K + 64	bytes
2048 x 64	64	-	Pages
2048	-	-	Blocks

Figure 4 Array Organization

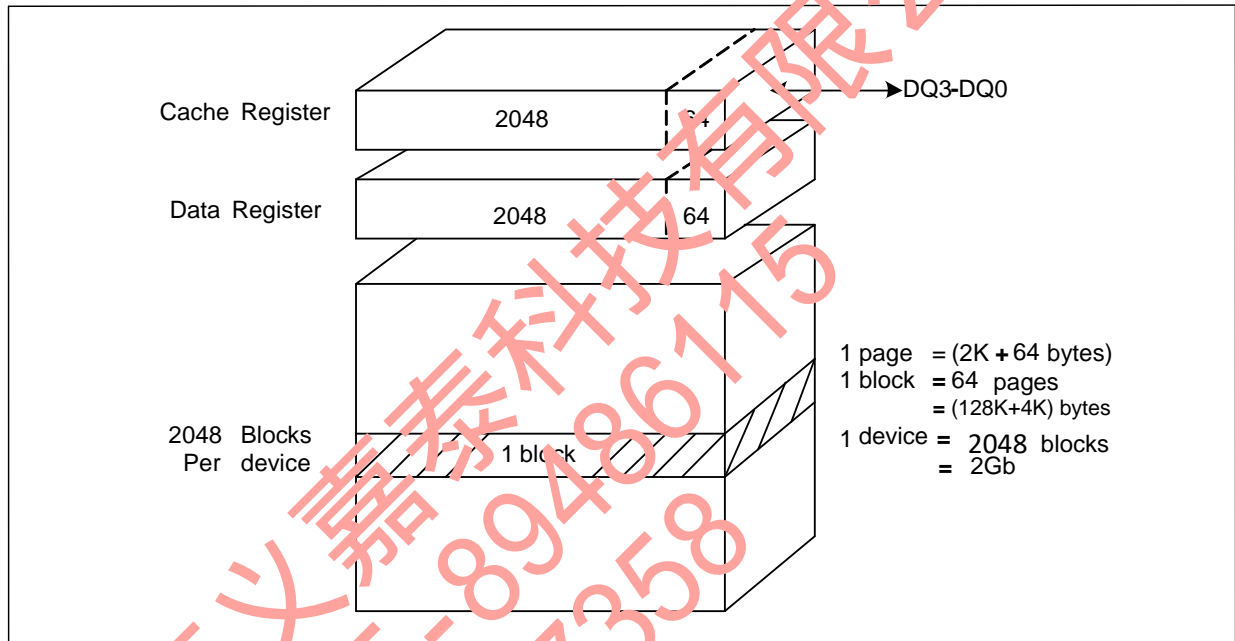

5. DEVICE OPERATION

6.1. SPI Modes

.Standard SPI

The XT26G02A is accessed through an SPI compatible bus consisting of four signals: Serial Clock (CLK), Chip Select (CS#), Serial Data Input (DI) and Serial Data Output (DO). Standard SPI instructions use the DI input pin to serially write instructions, addresses or data to the device on the rising edge of CLK. The DO output pin is used to read data or status from the device on the falling edge of CLK.

SPI bus operation Mode 0 (0,0) and 3 (1,1) are supported. The primary difference between Mode 0 and Mode 3 concerns the normal state of the CLK signal when the SPI bus master is in standby and data is not being transferred to the Serial Flash. For Mode 0, the CLK signal is normally low on the falling and rising edges of CS#. For Mode 3, the CLK signal is normally high on the falling and rising edges of CS#.

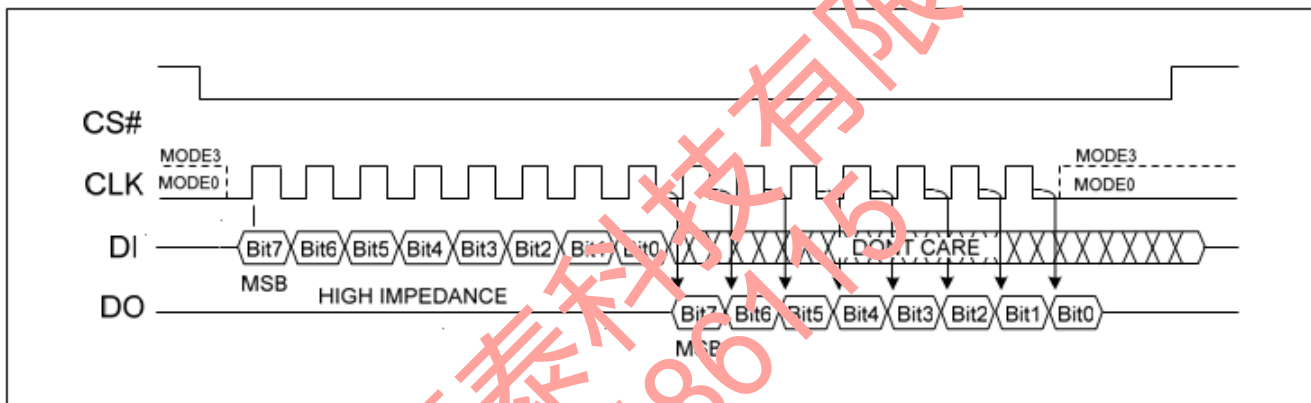

SPI SDR Modes Supported

.Dual SPI

The XT26G02A supports Dual SPI operation when using the x2 and dual IO instructions. These instructions allow data to be transferred to or from the device at two times the rate of ordinary Serial Flash devices. When using Dual SPI instructions, the DI and DO pins become bidirectional I/O pins: DQ0 and DQ1.

.Quad SPI

The XT26G02A supports Quad SPI operation when using the x4 and Quad IO instructions. These instructions allow data to be transferred to or from the device four times the rate of ordinary Serial Flash. When using Quad SPI instructions the DI and DO pins become bidirectional DQ0 and DQ1 and the WP # and HOLD# pins become DQ2 and DQ3 respectively. Quad SPI instructions require the Quad Enable bit (QE) to be set.

6.2. Pin Function Description

CS#

The SPI Chip Select (CS#) pin enables and disables device operation. When CS# is high, the device is deselected and the Serial Data Output (DO, or DQ0, DQ1, DQ2, DQ3) pins are at high impedance. When deselected, the devices power consumption will be at standby levels unless an internal erase, program or write status register cycle is in progress. When CS# is brought low, the device will be selected, power consumption will increase to active levels and instructions can be written to and data read from the device. After power-up, CS# must transition from high to low before a new instruction will be accepted.

CLK

This input signal provides the synchronization reference for the SPI interface. Instructions, addresses, or data input are latched on the rising edge of the CLK signal. Data output changes after the falling edge of CLK.

Serial Input (DI) / DQ0

This input signal is used to transfer data serially into the device. It receives instructions, addresses, and data to be programmed. Values are latched on the rising edge of serial CLK clock signal.

DI becomes DQ0 – an input and output during Dual and Quad commands for receiving instructions, addresses, and data to be programmed (values latched on rising edge of serial CLK clock signal) as well as shifting out data (on the falling edge of CLK).

Serial Output (DO) / DQ1

This output signal is used to transfer data serially out of the device. Data is shifted out on the falling edge of the serial CLK clock signal.

DO becomes DQ1 – an input and output during Dual and Quad commands for receiving addresses, and data to be programmed (values latched on rising edge of serial CLK clock signal) as well as shifting out data (on the falling edge of CLK).

Write Protect (WP#) / DQ2

When WP# is driven Low (VIL) during a SET FEATURES command and while the BRWD bit of the Status Register is set to a 1, it is not possible to write to the Status Registers. This prevents any alteration of the Block Protect (BP2, BP1, BP0), INV and CMP bits of the Status Register. As a consequence, all the data bytes in the memory area that are protected by the Block Protect (BP2, BP1, BP0), INV and CMP bits, are also hardware protected against data modification if WP# is Low during a SET FEATURES command. The WP# function is not available when the Quad mode is enabled (QE=1).

The WP# function is replaced by DQ2 for input and output during Quad mode for receiving addresses, and data to be programmed (values are latched on rising edge of the CLK signal) as well as shifting out data (on the falling edge of CLK).

Hold (HOLD#) / DQ3

For Standard SPI and Dual SPI operations, the HOLD# signal allows the XT26G02A operation to be paused while it is actively selected (when CS# is low). The HOLD# function may be useful in cases where the SPI data and clock signals are shared with other devices. For example, consider if the page buffer was only partially written when a priority interrupt requires use of the SPI bus. In this case the HOLD# function can save the state of the instruction and the data in the buffer so programming can resume where it left off once the bus is available again. Note:” HOLD#” pin require an external pull-up resistor to avoid accidental operation being placed on hold.

To initiate a HOLD# condition, the device must be selected with CS# low. A HOLD# condition will activate on the falling edge of the HOLD# signal if the CLK signal is already low. If the CLK is not already low the HOLD# condition will activate after the next falling edge of CLK. The HOLD# condition will terminate on the rising edge of the HOLD# signal if the CLK signal is already low. If the CLK is not already low the HOLD# condition will terminate after the next falling edge of CLK. During a HOLD# condition, the Serial Output (DO) is high impedance, and Serial Input (DI) and Serial Clock (CLK) are ignored. The Chip Select (CS#) signal should be kept active (low) for the full duration of the HOLD# operation to avoid resetting the internal logic state of the device.

The HOLD# function is not available when the Quad mode is enabled (QE =1). The Hold function is replaced by DQ3 for input and output during Quad mode for receiving addresses, and data to be programmed (values are latched on rising edge of the CLK signal) as well as shifting out data (on the falling edge of CLK).

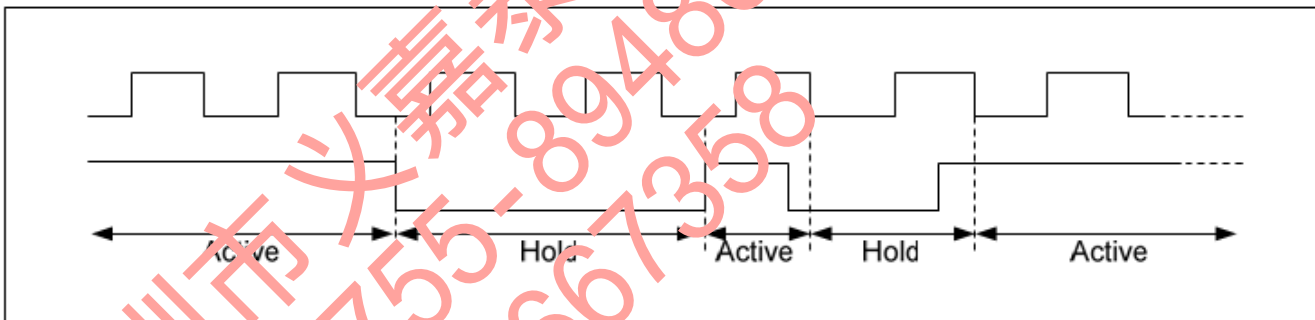

Figure 3 Hold Condition Waveform

6.3. Command Set Tables

Table 1 Standard SPI Command Set

INSTRUCTION NAME	BYTE 1	BYTE 2	BYTE 3	BYTE 4	BYTE 5	BYTE N
WRITE ENABLE	06h					
WRITE DISABLE	04h					
GET FEATURES	0Fh	A7-A0	(D7-D0)			
SET FEATURES	1Fh	A7-A0	D7-D0			
PAGE READ	13h	A23-A16	A15-A7	A7-A0		
READ FROM CACHE	03h/0Bh	A15-A8 ⁽²⁾	A7-A0	dummy	(D7-D0)	wrap
Read ID	9Fh	00 ⁽⁸⁾	(MID) ⁽⁸⁾	(DID) ⁽⁸⁾		wrap
PROGRAM LOAD	02h	A15-A8 ⁽⁶⁾	A7-A0	D7-D0	Next byte	Byte N
PROGRAM LOAD RANDOM DATA ⁽⁹⁾	84h	A15-A8 ⁽⁶⁾	A7-A0	D7-D0	Next byte	Byte N
Program Execute	10h	A23-A16	A15-A7	A7-A0		
BLOCK ERASE	D8h	A23-A16	A15-A7	A7-A0		
Reset	FFh					

Table 2 Dual SPI Command Set

INSTRUCTION NAME	BYTE 1	BYTE 2	BYTE 3	BYTE 4	BYTE 5	BYTE N
READ FROM CACHE x 2	3Bh	A15-A8 ⁽²⁾	A7-A0	dummy	(D7-D0)x2	wrap
READ FROM CACHE DUAL IO	3Bh	A15-A0 ⁽³⁾	dummy ⁽⁴⁾	(D7-D0)x2		wrap

Table 3 Quad SPI Command Set

INSTRUCTION NAME	BYTE 1	BYTE 2	BYTE 3	BYTE 4	BYTE 5	BYTE N
READ FROM CACHE x4	6Bh	A15-A8 ⁽²⁾	A7-A0	dummy	(D7-D0)x4	wrap
READ FROM CACHE QUAD IO	Ebh	A15-A0 ⁽⁵⁾	(D7-D0)x4			wrap
PROGRAM LOAD x4	32h	A15-A8 ⁽⁶⁾	A7-A0	D7-D0 x4	Next byte	Byte N
PROGRAM LOAD RANDOM DATA x4 ⁽⁹⁾	84h/4h	A15-A8 ⁽⁶⁾	A7-A0	D7-D0 x4	Next byte	Byte N
PROGRAM LOAD RANDOM DATA Quad IO ⁽⁷⁾	72h	A15-A0 ⁽⁷⁾	D7-D0 x4	Next byte		Byte N

Notes:

1. Data bytes are shifted with Most Significant Bit first. Byte fields with data in parenthesis “()” indicate data output from the device on either 1, 2 or 4 DQ pins.
2. The x8 clock = wrap<3:0>, A11-A8
3. The x2 clock = wrap<3:0>, A11-A0
4. The x4 clock = dummy<7:0>,D7-D0
5. The x8 clock = wrap<3:0>,A11-A0,dummy<7:0>,D7-D0
6. The x8 clock = dummy<3:0>,A11-A8
7. The x8 clock = dummy<3:0>,A11-A0,D7-D0,D7-D0
8. MID is Manufacture ID(0Bh for XT), DID is Device ID(E2h for current device), Accept Byte=00 only after 0x9F
9. Only available in Internal Data Move operation

6.4. WRITE OPERATIONS

6.4.1. Write Enable (WREN) (06H)

The WRITE ENABLE (WREN) command sets the WEL bit in the status register to 1. The WEL bit must be set prior to following operations that changes the contents of the memory array:

- Page Program
- OTP Program
- OTP Lock
- BLOCK ERASE

Figure4. Write Enable Sequence Diagram

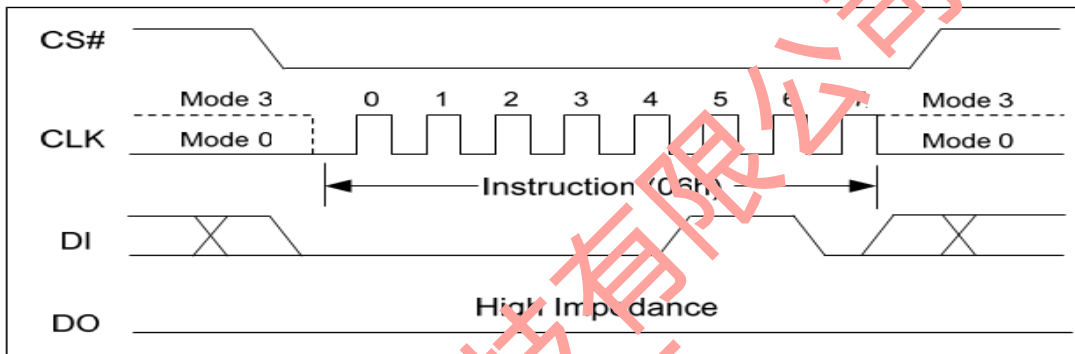

6.4.2. WRITE DISABLE (WRDI) (04h)

The WRITE DISABLE (WRDI) command resets the WEL bit in the status register to 0. The WEL bit is automatically reset after Power-up and upon completion of the following operations:

- Page Program
- OTP Program
- OTP Lock
- BLOCK ERASE

Figure5. Write Disable Sequence Diagram

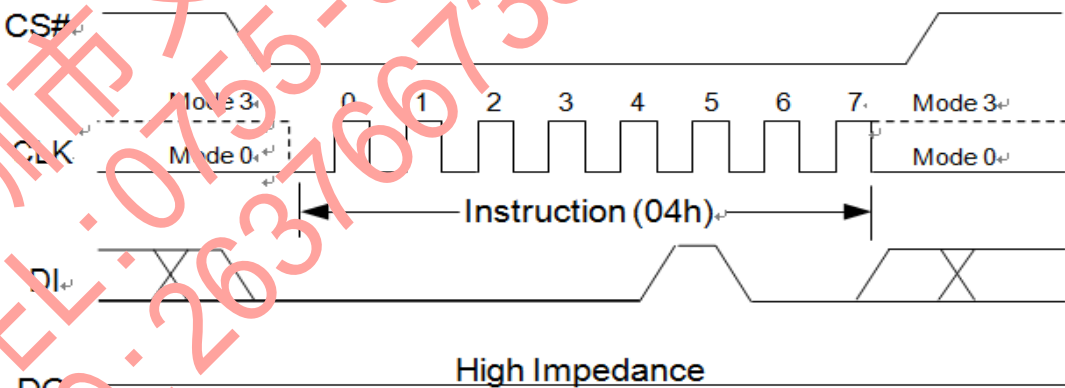

6.5. FEATURE OPERATIONS

Get Features (0Fh) and Set Features (1Fh)

The GET FEATURES (0Fh) and SET FEATURES (1Fh) commands are used to alter the device behavior from the default power-on behavior. These commands use a 1-byte feature address to determine which feature is to be read or modified. Features such as OTP and block locking can be enabled or disabled by setting specific bits in feature address A0h and B0h (shown the following table). The status register is mostly read, except WEL, which is writable bit with the WREN (06h) command.

When a feature is set, it remains active until the device is power cycled or the feature is written to. Unless otherwise specified in the following table, once the device is set, it remains set, even if a RESET (FFh) command is issued.

Table2. Features Settings

Register	Address	Data Bits							
		7	6	5	4	3	2	1	0
Block Lock	A0h	BRWD	Reserved	BP2	BP1	BP0	INV	CMP	Reserved
Feature	B0h	OTP_PRT	OTP_EN	Reserved	ECC_FAIL	Reserved	Reserved	Reserved	QE
Status	C0h	Reserved	Reserved	ECCS3	ECCS2	P_FAIL/ ECCS1	E_FAIL/ ECCS0	WEL	OIP

Note:

1. If BRWD is enabled and WP# is low, then the Block lock register (BP2-BP0, INV and CMP) cannot be changed.
2. If QE is enabled, the quad IO operations can be executed.
3. All the reserved bits must be held low when the feature is set.
4. The features in the feature byte P0h are all volatile except OTP_PRT bit.
5. BIT2(E_FAIL) and BIT3(P_FAIL) of status register (C0h) is multiplexed with ECC status bits (ECCS1/ECCS0).
6. After page read command (00h), the BIT2-BIT3 reflects the ECC flip bit status (please refer to page27(section 8) for detail)
7. P_FAIL and E_FAIL reflects the result of last program/erase operation

Figure9. Get Features Sequence Diagram

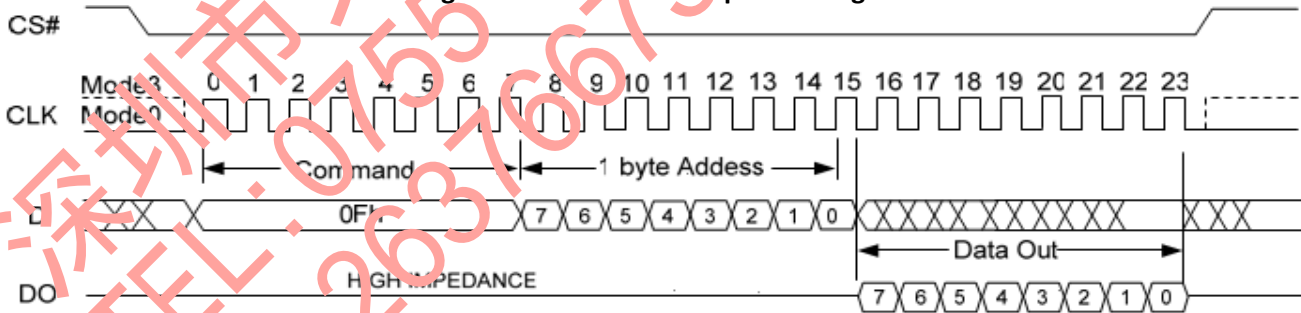
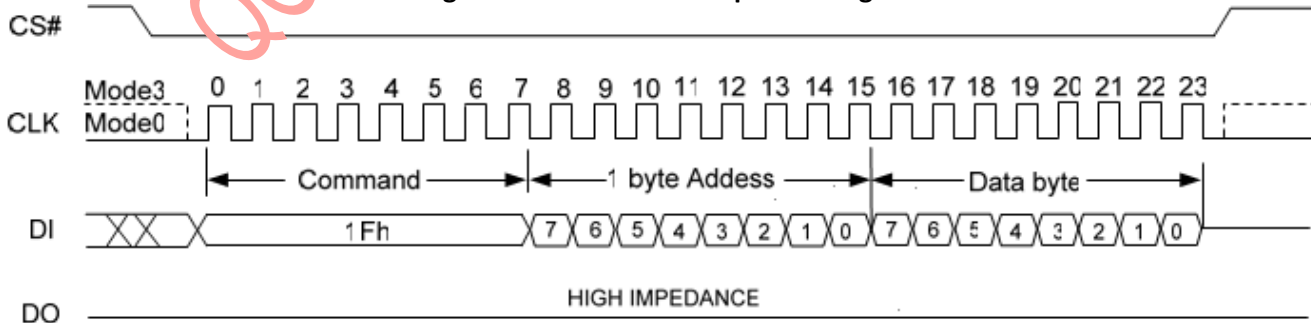

Figure10. Set Features Sequence Diagram



6.6 READ OPERATIONS

6.6.1. Page Read

The PAGE READ (13h) command transfers the data from the NAND Flash array to the cache register. The command sequence is follows:

1. 13h (PAGE READ TO CACHE)
2. 0Fh (GET FEATURES command to read the status)
3. 0Bh or 03h (READ FROM CACHE)
4. READ FROM CACHE Operation
 - a) 3Bh (READ FROM CACHE x2)
 - b) 6Bh (READ FROM CACHE x4)
 - c) BBh (READ FROM CACHE DUAL IO)
 - d) Ebh (READ FROM CACHE QUAD IO)

The PAGE READ command requires a 24-bit address consisting of 7 dummy bits followed by an 17-bit block/page address. After the block/page addresses are registered, the device starts the transfer from the main array to the cache register, and is busy for tRD time. During this time, the GET FEATURE (0Fh) command can be issued to monitor the status of the operation (refer to the Status Register section). Following a status of successful completion, the READ FROM CACHE (03h/0Bh/3Bh/6Bh/BBh/Ebh) command must be issued in order to read the data out of the cache.

The READ FROM CACHE command requires 4 wrap mode configure bits, followed by 12-bit column address for the starting byte address. The starting byte address must be in 0 to 2111. After the end of the cache register is reached, the data wraps around the beginning boundary automatically until CS# is pulled high to terminate this operation.

Table 3. Wrap configure bit table

Wrap<3:0>	Wrap Length (byte)
00xx	2112
01xx	2048
10xx	64
11xx	16

6.6.2. Page Read to Cache (13H)

Command 13h transfers data from the data register to the cache register (see Figure 11 for details). The ECC Enable bit (ECC_EN) of feature (B0 [4]) must be set to enable for the page read to buffer command.

Figure11. Page Read to cache Sequence Diagram

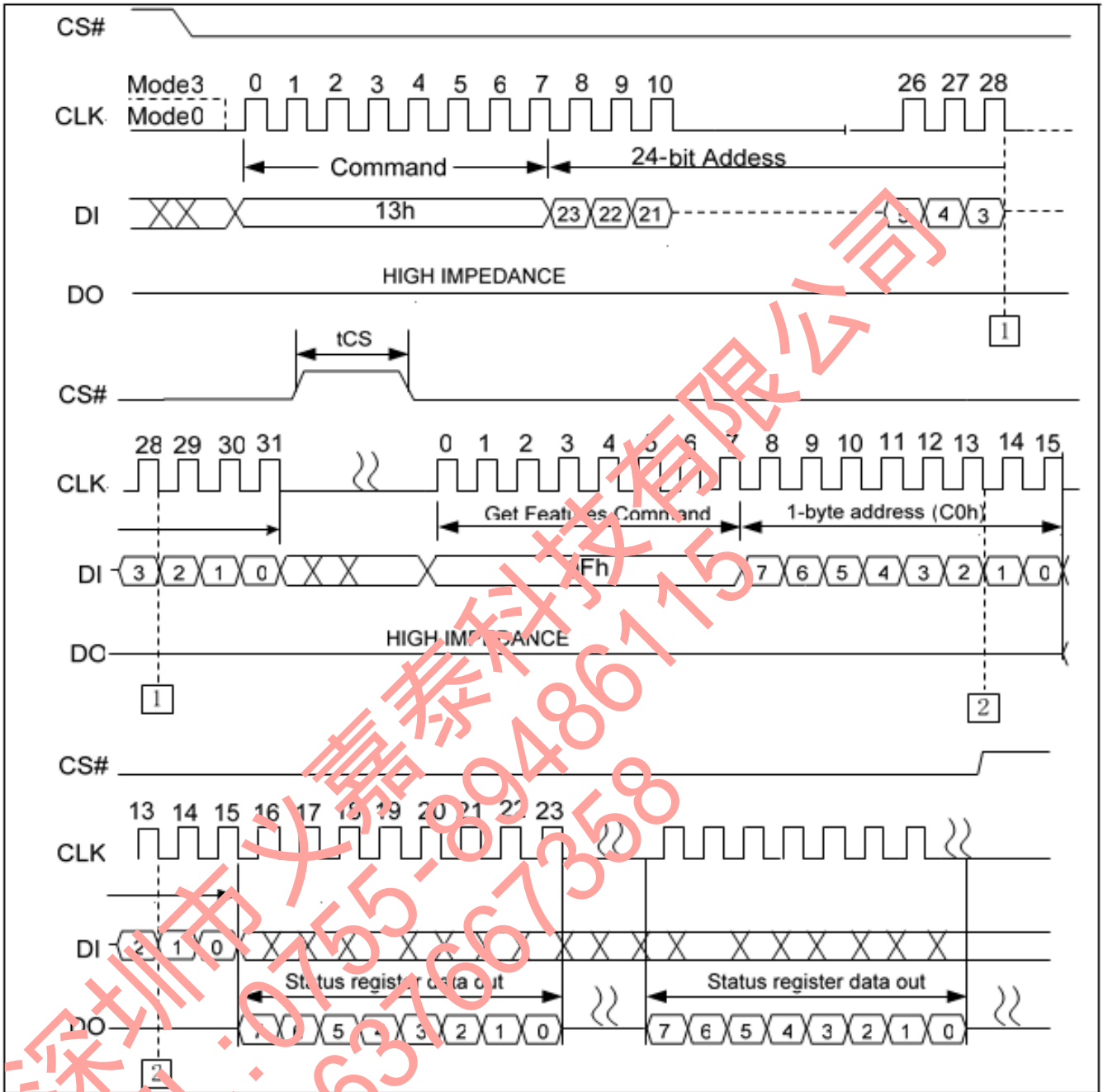

6.6.2. Read From Cache (03H or 0BH)

Figure12. Read From Cache Sequence Diagram

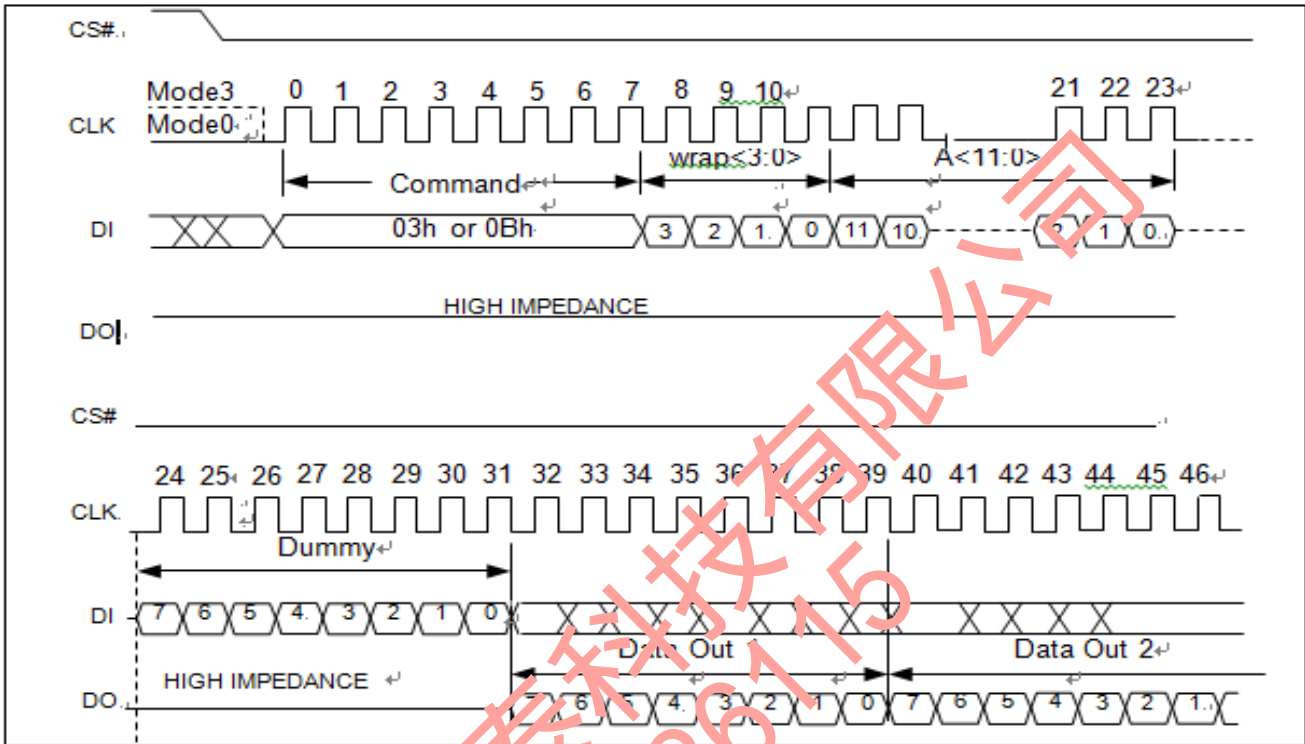

6.6.3. Read From Cache x2 (33h)

Figure13. Read From Cache x2 Sequence Diagram

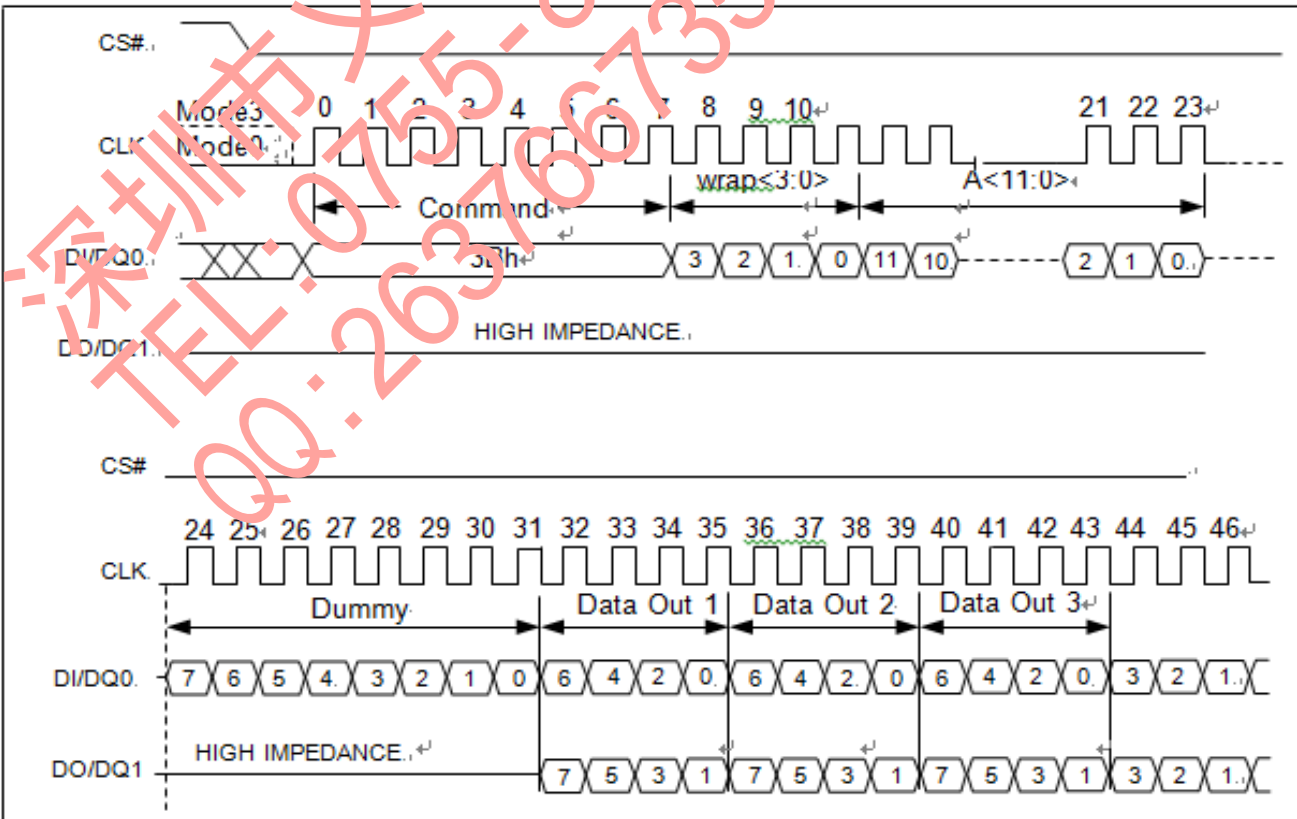

6.6.4. Read From Cache x4 (6BH)

The Quad Enable bit (QE) of feature (B0 [0]) must be set to enable for the read from cache x4 command. The ECC Enable bit (ECC_EN) of feature (B0 [4]) must be set to enable for the page read to buffer command

Figure12. Read From Cache x4 Sequence Diagram

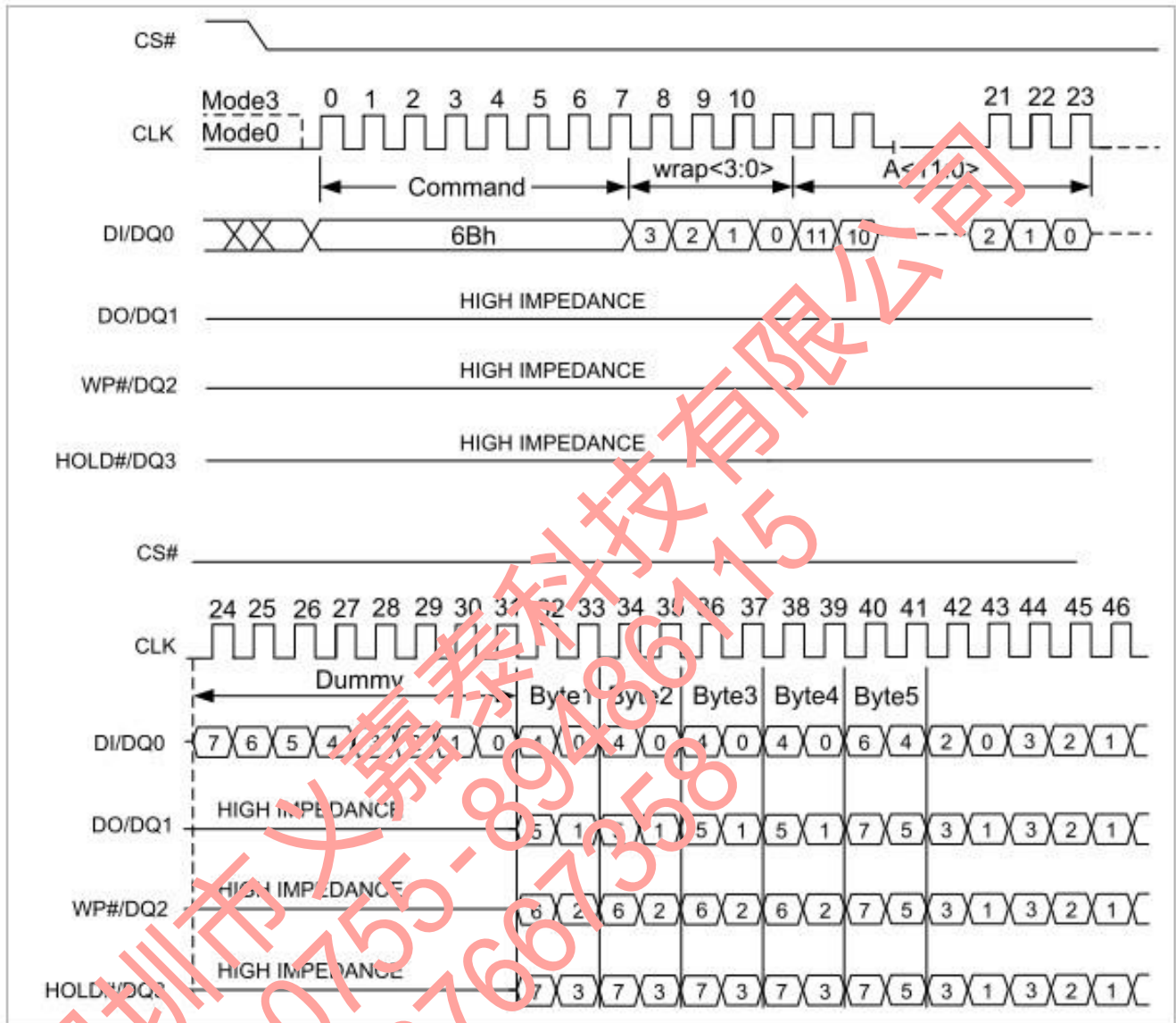

6.6.5. Read From Cache Dual IO (BBH)

The Read from Cache Dual I/O command (BBH) is similar to the Read from Cache x2 command (3BH) but with the capability to input the 4 Wrap bits, followed by a 12-bit column address for the starting byte address and a dummy byte by SIO0 and SIO1, each bit being latched in during the rising edge of SCLK, then the cache contents are shifted out 2-bit per clock cycle from DQ0 and DQ1. The first byte addressed can be at any location. The address is automatically incremented to the next higher address after each byte of data is shifted out until the boundary by the Wrap<3:0>.

Figure13. Read From Cache Dual IO Sequence Diagram

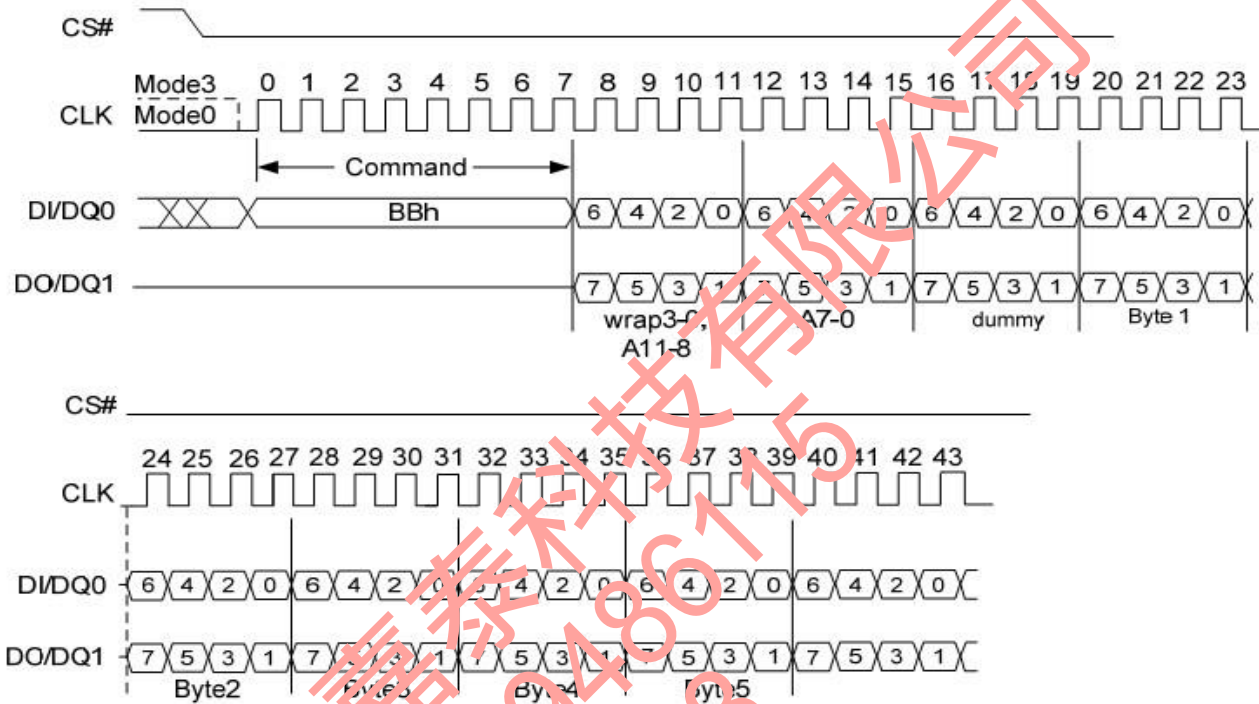

6.6.6. Read From Cache Quad IO (EBH)

The Read from Cache Quad IO command is similar to the Read from Cache x4 command but with the capability to input the 4 wrap bits followed a 12-bit column address for the starting byte address and a dummy byte by DQ0, DQ1, DQ2, DQ3, each bit being latched in during the rising edge of SCLK, then the cache contents are shifted out 4 bit per clock cycle from DQ0, DQ1, DQ2, DQ3. The first byte addressed can be at any location. The address is automatically incremented to the next higher address after each byte of data is shifted out until the boundary by the Wrap<3:0>. The Quad Enable bit (QE) of feature (B0 [0]) must be set to enable for the read from cache quad IO command. The ECC Enable bit (ECC_EN) of feature (B0 [4]) must be set to enable for the page read to buffer command.

Figure 14. Read From Cache Quad IO Sequence Diagram

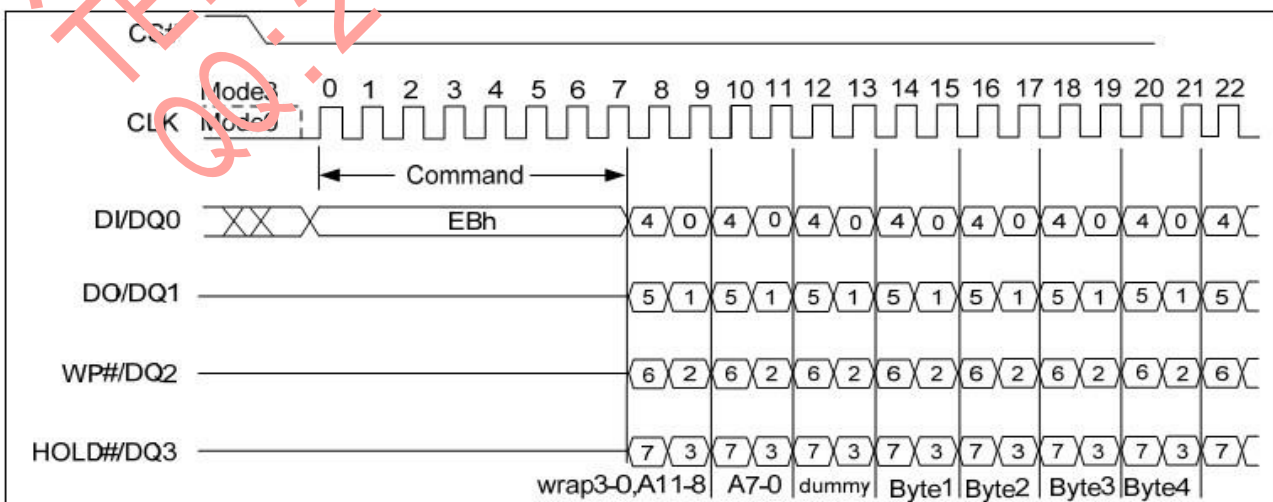

6.6.7. Read ID (9FH)

The READ ID command is used to read the 2 bytes of identifier code programmed into the NAND Flash device. The READ ID command reads a 2-byte table (see below) that includes the Manufacturer ID and the device configuration.

Figure15. Read ID Sequence Diagram

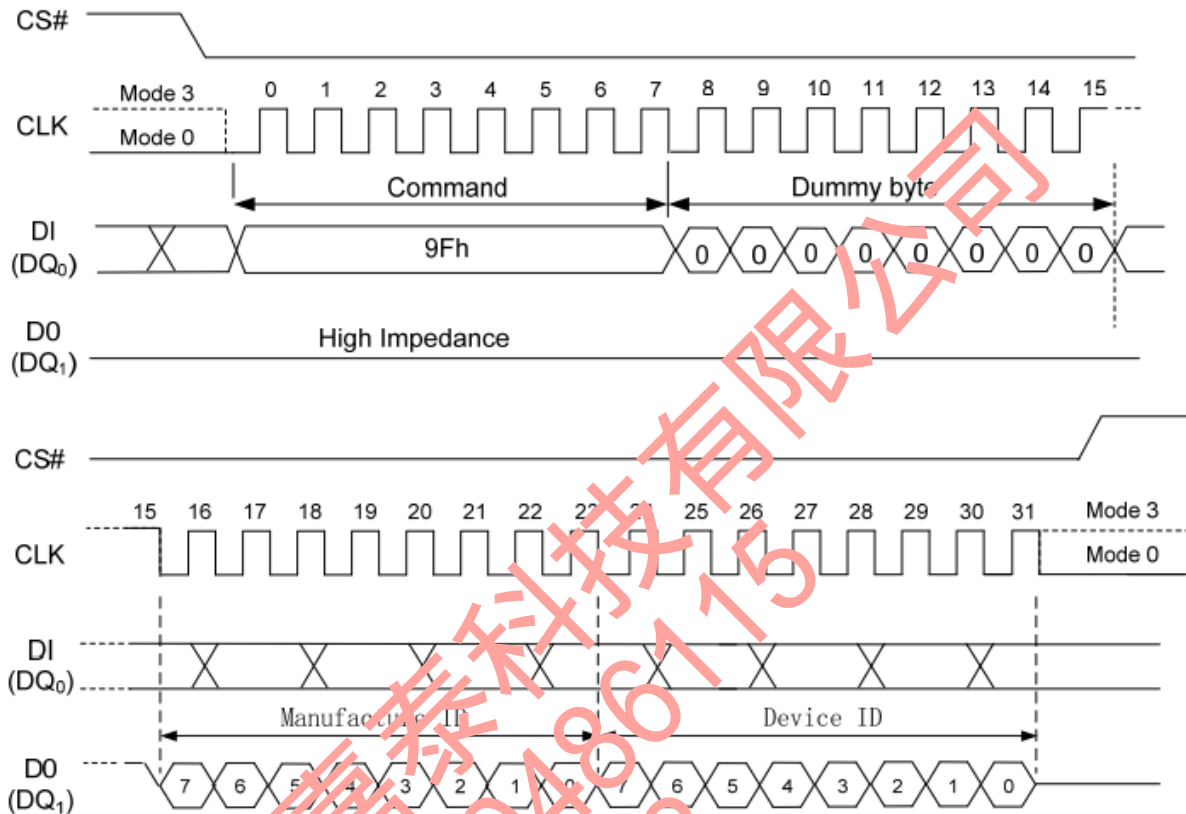

Table4. READ ID Table

Address	Value	Description
Byte 0	0FH	Manufacture ID (XTX)
Byte 1	2FH	Device ID (SPI NAND 2Gbit)

6.7. PROGRAM OPERATIONS

6.7.1 Page Program

The PAGE PROGRAM operation sequence programs 1 byte to 2112 bytes of data within a page. The page program sequence is as follows:

- 02H (PROGRAM LOAD)/32H (PROGRAM LOAD x4)
- 06H (WRITE ENABLE)
- 10H (PROGRAM EXECUTE)
- 0FH (GET FEATURE command to read the status)

The 1st step is to issue a PROGRAM LOAD (02H/32H) command. PROGRAM LOAD consists of an 8-bit Op code, followed by 4 dummy bits and a 12-bit column address, then the data bytes to be programmed. The data bytes are loaded into a cache register which is 2112 bytes long. If more than 2112 bytes are loaded, then those additional bytes are ignored by the cache register. The command sequence ends when CS# goes from LOW to HIGH. Figure 19 shows the PROGRAM LOAD operation.

The 2nd step, prior to performing the PROGRAM EXECUTE operation, is to issue a WRITE ENABLE (06H) command. As with any command that changes the memory content, the WRITE ENABLE must be executed in order to set the WEL bit. If this command is not issued, then the rest of the program sequence is ignored.

The 3rd step is to issue a PROGRAM EXECUTE (10H) command to initiate the transfer of data from the cache register to the main array. PROGRAM EXECUTE consists of an 8-bit Op code, followed by a 24-bit address (7 dummy bits and an 17-bit page/block address). After the page/block address is registered, the memory device starts the transfer from the cache register to the main array, and is busy for tPROG time. This operation is shown in Figure 21.

During this busy time, the status register can be polled to monitor the status of the operation (refer to the Status Register section). When the operation completes successfully, the next series of data can be loaded with the PROGRAM LOAD command.

NOTE : The number of consecutive partial page programming operations (NOP) within the same page must not exceed 4. In addition, pages must be sequentially programmed within a block.

6.7.2. Program Load (PL) (02H)

Figure16. Program Load Sequence Diagram

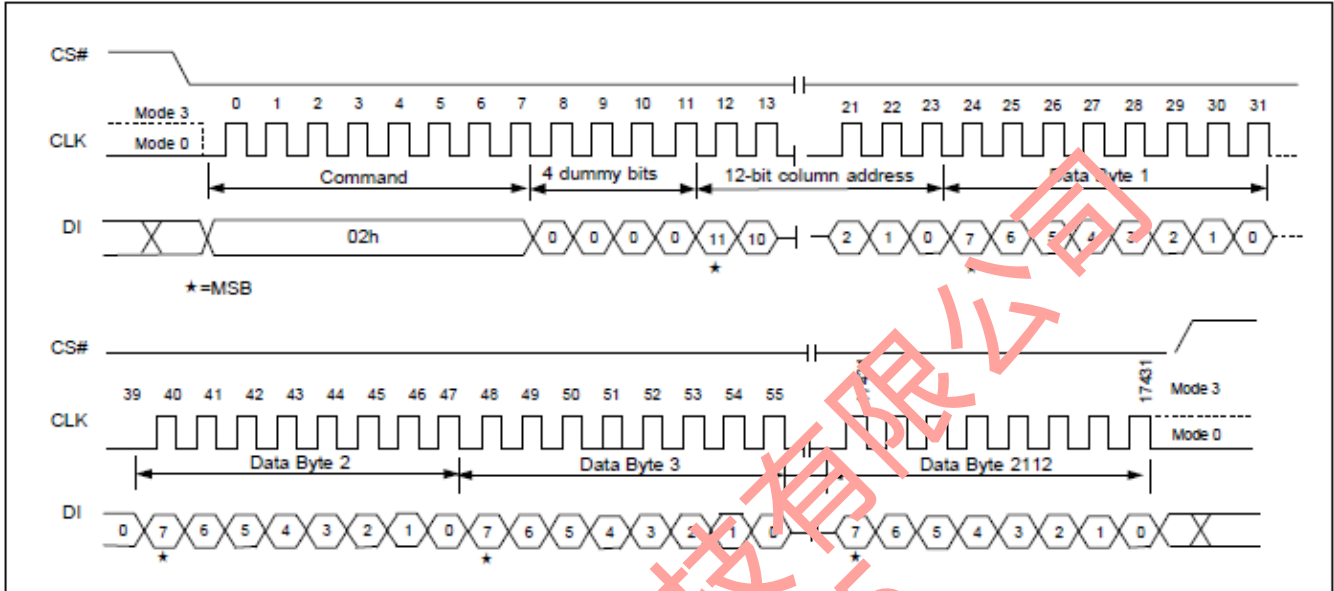

6.7.3. Program Load x4 (PL x4) (32H)

The Program Load x4 command (32H) is similar to the Program Load command (02H) but with the capability to input the data bytes by four pins: DQ0, DQ1, DQ2, and DQ3. The command sequence is shown below. The Quad Enable bit (QE) of feature (B0 [0]) must be set to enable for the program load x4 command.

Figure 27. Program Load x4 Sequence Diagram

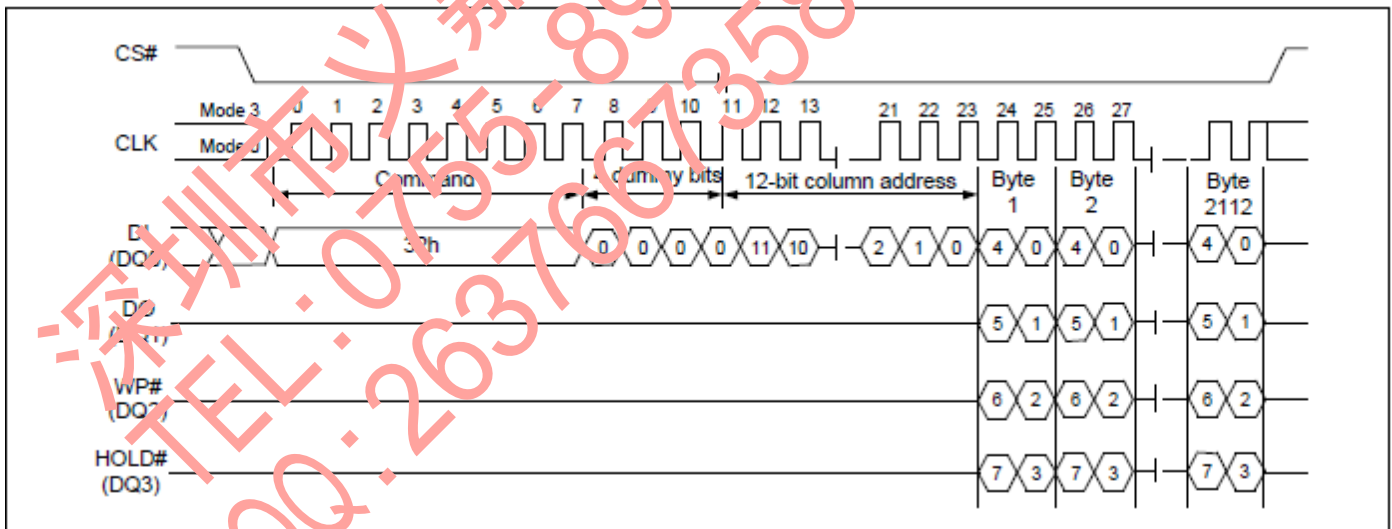

6.7.4. Program Execute (PE) (10H)

After the data is loaded, a PROGRAM EXECUTE (10H) command must be issued to initiate the transfer of data from the cache register to the main array. PROGRAM EXECUTE consists of an 8-bit Op code, followed by a 24-bit address (7 dummy bits and a 17-bit page/block address). After the page/block address is registered, the memory device starts the transfer from the cache register to the main array, and is busy for t_{PROG} time. This operation is shown in Figure17. During this busy time, the status register can be polled to monitor the status of the operation (refer to Status Register). When the operation completes successfully, the next series of data can be loaded with the PROGRAM LOAD command.

Figure18. Program Execute Sequence Diagram

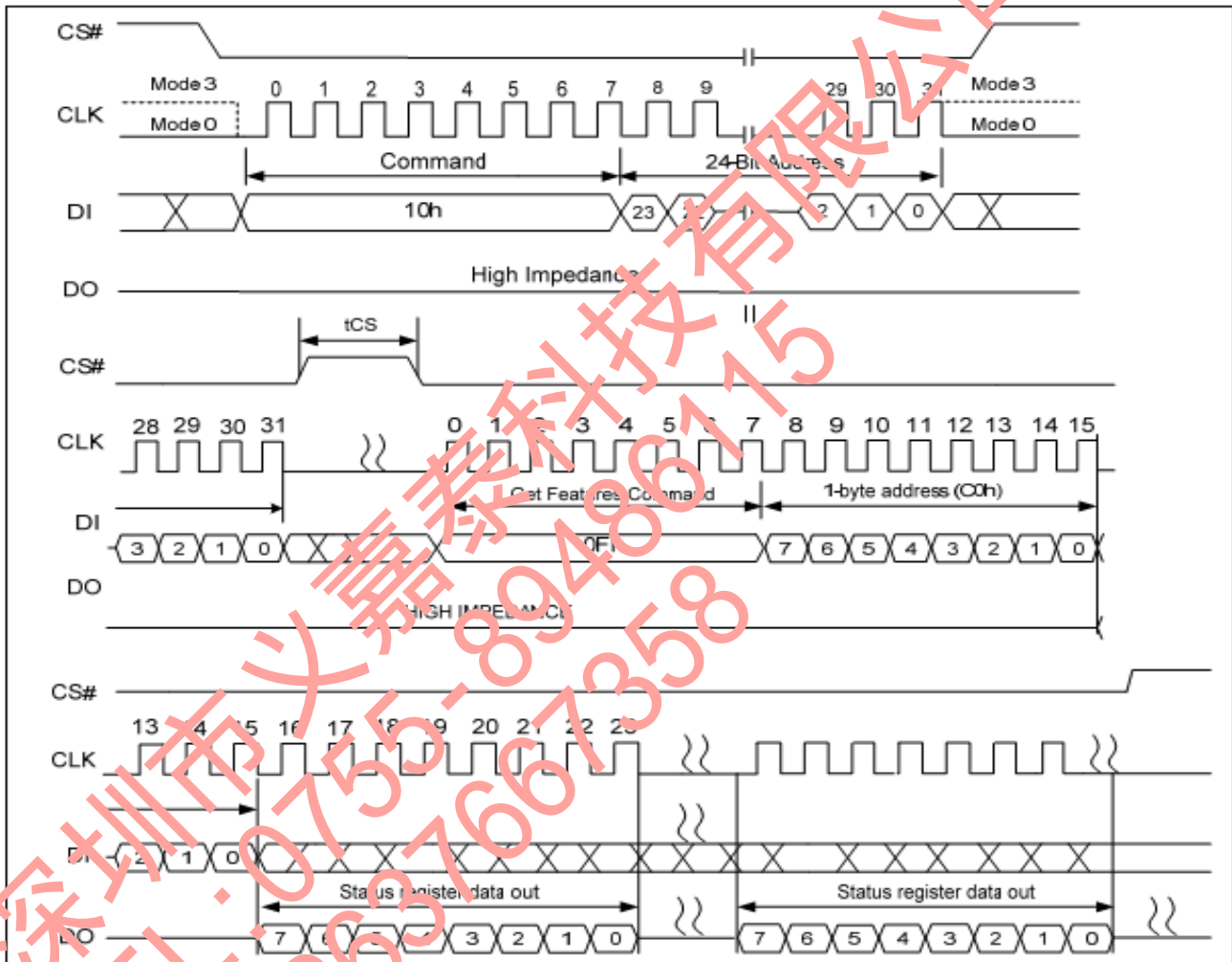

6.7.5. Internal Data Move

The Internal Data Move command sequence programs or replaces data in a page with existing data. The Internal Data Move command sequence is as follows:

- 13H (PAGE READ TO CACHE)
- 84H/C4H/ 34H/72H(PROGRAM LOAD RANDOM DATA : Optional)
- 06H (WRITE ENABLE)
- 10H (PROGRAM EXECUTE)
- 0FH (GET FEATURE command to read the status)

Prior to performing an internal data move operation, the target page content must be read out into the cache register by issuing a PAGE READ (13H) command. The PROGRAM LOAD RANDOM DATA (84H/C4H/34H/72H) command can be issued, if user wants to update bytes of data in the page.

This command consists of an 8-bit Op code, followed by 4 dummy bits and a 12-bit column address. New data is loaded in the 12-bit column address. If the RANDOM DATA is not sequential, another PROGRAM LOAD RANDOM DATA (84H/C4H/34H/72H) command must be issued with the new column address. After the data is loaded, the WRITE ENABLE command must be issued, then a PROGRAM EXECUTE (10H) command can be issued to start the programming operation.

6.7.6. Program Load Random Data (84H)

This command consists of an 8-bit Op code, followed by 4 dummy bits, and a 12-bit column address. New data is loaded in the column address provided with the 12 bits. If the random data is not sequential, then another PROGRAM LOAD RANDOM DATA (84h) command must be issued with a new column address. After the data is loaded, a PROGRAM EXECUTE (10h) command can be issued to start the programming operation.

Figure 20 Program Load Random Data Sequence Diagram

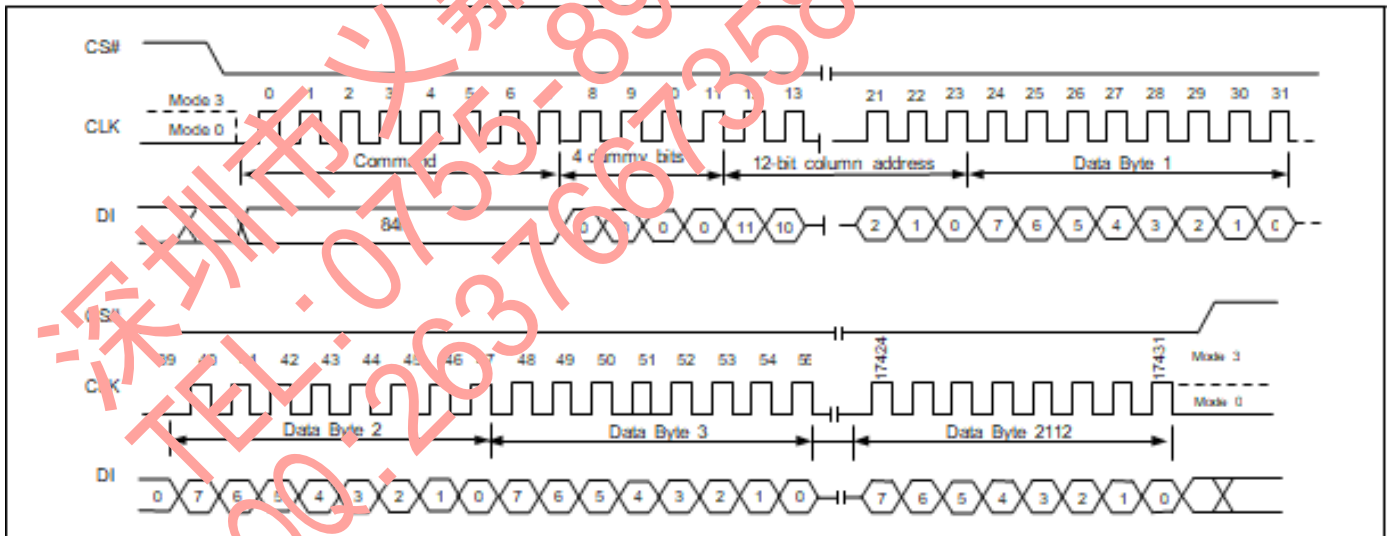

6.7.7. Program Random Data x4 (C4H/34H)

The Program Load Random Data x4 command (C4H) is similar to the Program Load Random Data command (84H) but with the capability to input the data bytes by four pins: DQ0, DQ1, DQ2, and DQ3. The command sequence is shown below. The Quad Enable bit (QE) of feature (B0 [0]) must be set to enable for the program load random data x4 command.

Figure21. Program Load Random Data x4 Sequence Diagram

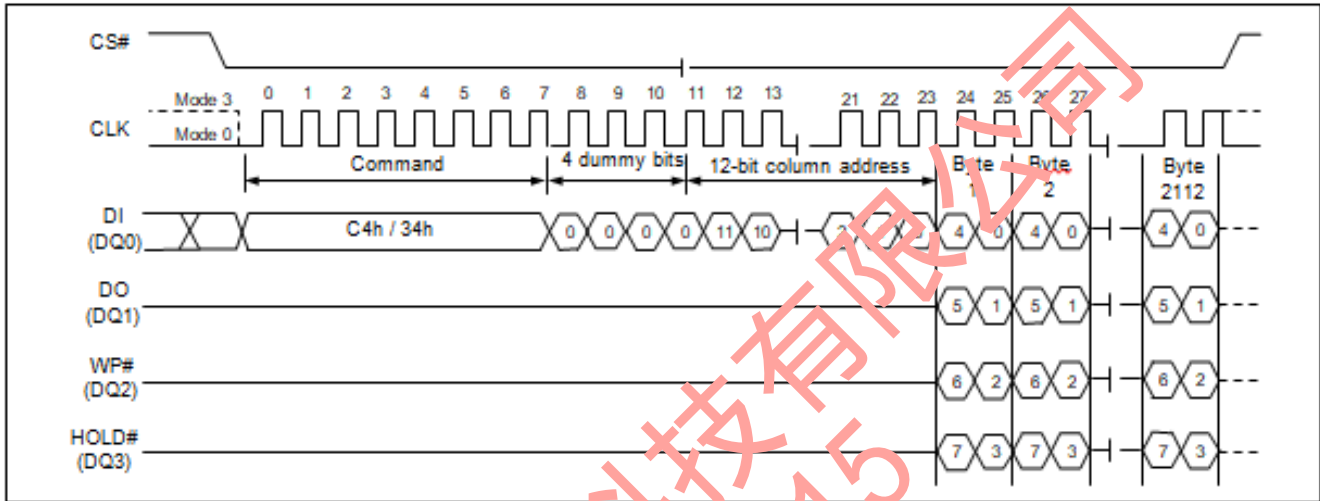

6.7.8. Program Random Quad IO (72H)

The Program Load Random Data Quad IO command (72H) is similar to the Program Load Random Data x4 command (C4H) but with the capability to input the 4 dummy bits, and a 12-bit column address by four pins: DQ0, DQ1, DQ2, and DQ3. The command sequence is shown below. The Quad Enable bit (QE) of feature (B0 [0]) must be set to enable for the program load random data x4 command.

Figure22. Program Load Random Data Quad IO Sequence Diagram

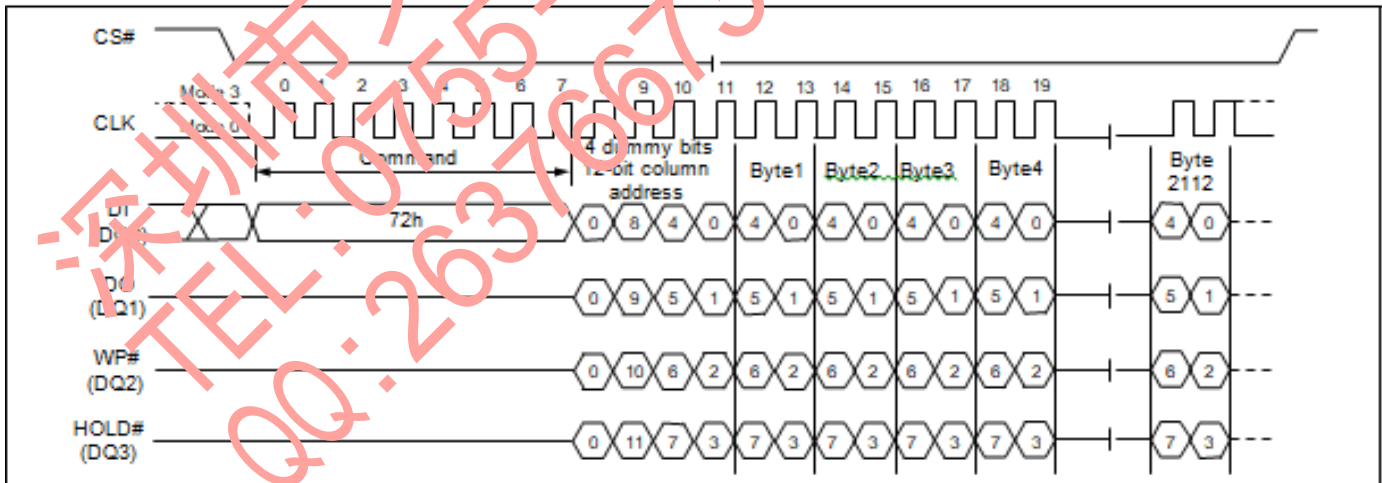

6.8. ERASE OPERATIONS

Block Erase (D8H)

The BLOCK ERASE (D8h) command is used to erase at the block level. The blocks are organized as 64 pages per block, 2112 bytes per page (2048+64 bytes). Each block is 132 Kbytes. The BLOCK ERASE command (D8h) operates on one block at a time. The command sequence for the BLOCK ERASE operation is as follows:

- 06h (WRITE ENABLE command)
- D8h (BLOCK ERASE command)
- 0Fh (GET FEATURES command to read the status register)

Prior to performing the BLOCK ERASE operation, a WRITE ENABLE (06h) command must be issued. As with any command that changes the memory contents, the WRITE ENABLE command must be executed in order to set the WEL bit. If the WRITE ENABLE command is not issued, then the rest of the erase sequence is ignored. A WRITE ENABLE command must be followed by a BLOCK ERASE (D8h) command. This command requires a 24-bit address consisting of 7 dummy bits followed by an 17-bit row address. After the row address is registered, the control logic automatically controls timing and erase-verify operations. The device is busy for t_{ERS} time during the BLOCK ERASE operation. The GET FEATURES (0Fh) command can be used to monitor the status of the operation (refer to the Status Register section).

Note: When a BLOCK ERASE operation is in progress, user can issue READ FROM CACHE commands (03H/0BH/3BH/6BH/BBH/EBH) to read the data in the cache.

Figure23. Block Erase Sequence Diagram

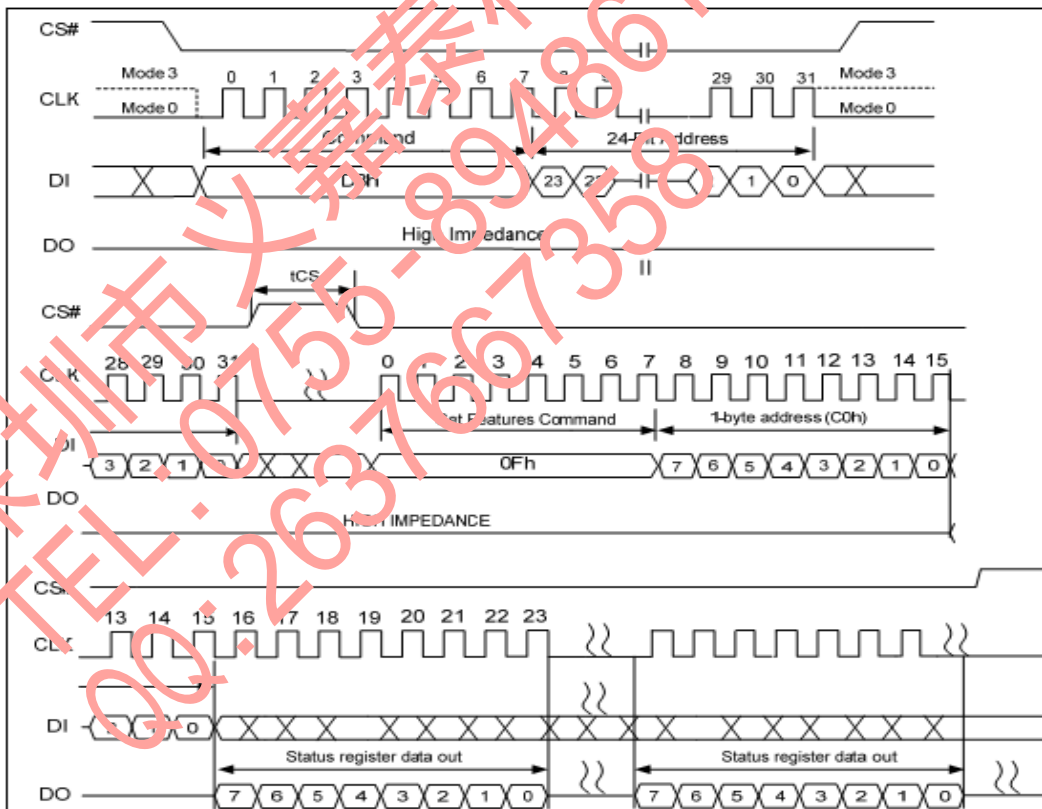

6.9. RESET Operation

The RESET (FFh) command stops all operations. For example, in case of a program or erase or read operation, the reset command can make the device enter the wait state.

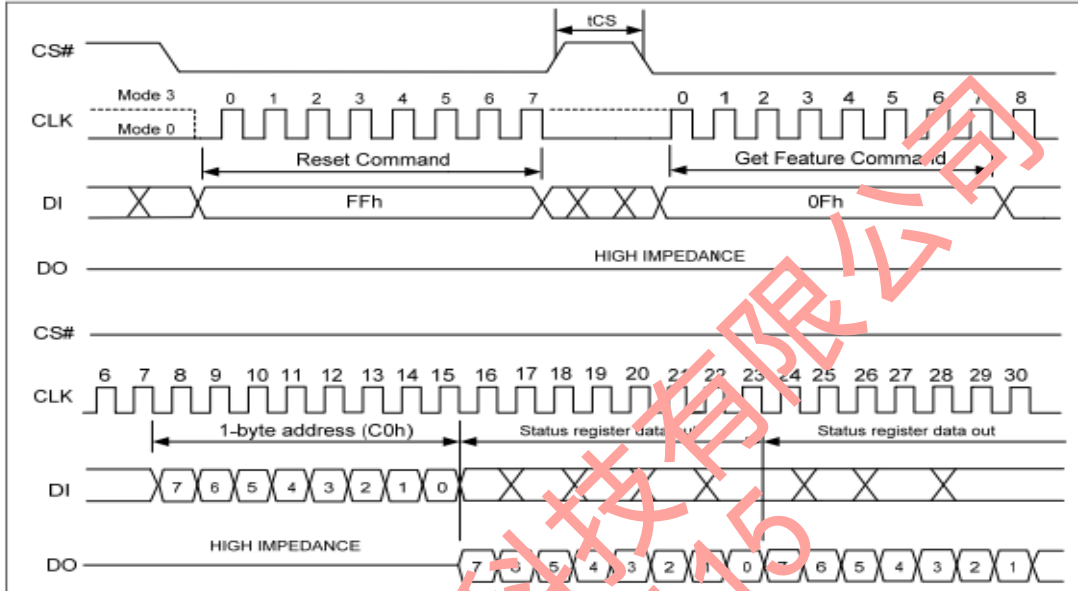

Figure 28 RESET (FFh) Timing

6.10. Write Protection

The write protection will be determined by the combination of CMP, INV, BP[2:0] bits in the Block Lock Register (A0).

Table 6 Block Lock Register Block Protect Bits

CMP	INV	BP2	BP1	BP0	Protected Row Address	Protected Rows
x	x	0	0	0	None	None
0	0	0	0	1	1F800h ~1FFFFh	Upper 1/64
0	0	0	1	0	1F000h ~1FFFFh	Upper 1/32
0	0	0	1	1	1E000h ~1FFFFh	Upper 1/16
0	0	1	0	0	1C000h ~1FFFFh	Upper 1/8
0	0	1	0	1	18000h ~1FFFFh	Upper 1/4
0	0	1	1	0	10000h ~1FFFFh	Upper 1/2
x	x	1	1	1	All (default)	All (default)
0	1	0	0	1	00000h ~007FFh	Lower 1/64
0	1	0	1	0	00000h ~00FFFh	Lower 1/32
0	1	0	1	1	00000h ~01FFFh	Lower 1/16
0	1	1	0	0	00000h ~03FFFh	Lower 1/8
0	1	1	0	1	00000h ~07FFFh	Lower 1/4
0	1	1	1	0	00000h ~0FFFFh	Lower 1/2
1	0	0	0	1	00000h ~1F7FFh	Lower 63/64
1	0	0	1	0	00000h ~1EFFFh	Lower 31/32
1	0	0	1	1	00000h ~1DFFFh	Lower 15/16
1	0	1	0	0	00000h ~1BFFFh	Lower 7/8

CMP	INV	BP2	BP1	BP0	Protected Row Address	Protected Rows
1	0	1	0	1	00000h ~17FFFh	Lower 3/4
1	0	1	1	0	00000h ~00003Fh	Block0
1	1	0	0	1	00800h ~1FFFFh	Upper 63/64
1	1	0	1	0	01000h ~1FFFFh	Upper 31/32
1	1	0	1	1	02000h ~1FFFFh	Upper 15/16
1	1	1	0	0	04000h ~1FFFFh	Upper 7/8
1	1	1	0	1	08000h ~1FFFFh	Upper 3/4
1	1	1	1	0	00000h ~00003Fh	Block0

深圳市义嘉泰科技有限公司
 TEL: 0755-89486115
 QQ: 2637667358

7. Status Register

The device has an 8-bit status register that software can read during the device operation for operation state query. The status register can be read by issuing the GET FEATURES (0FH) command, followed by the feature address C0h (see Feature Operation).

Table 7 Status Register Bit Description

Bit	Bit Name	Description
P_FAIL	Program Fail	This bit indicates that a program failure has occurred (P_FAIL set to 1). It will also be set if the user attempts to program an invalid address or a protected region, including the OTP area. This bit is cleared during the PROGRAM EXECUTE command sequence or a RESET command (P_FAIL = 0). This bit is only valid after a page programming command (0x10)
E_FAIL	Erase Fail	This bit indicates that an erase failure has occurred (E_FAIL set to 1). It will also be set if the user attempts to erase a locked region. This bit is cleared (E_FAIL = 0) at the start of the BLOCK ERASE command sequence or the RESET command. This bit is only valid after a block erase command (0xD8)
WEL	WRITE ENABLE Latch	This bit indicates the current status of the WRITE ENABLE latch (WEL) and must be set (WEL = 1), prior to issuing a PROGRAM EXECUTE or BLOCK ERASE command. It is set by issuing the WRITE ENABLE command. WEL can also be disabled (WEL = 0), by issuing the WRITE DISABLE command.
OIP	Operation In Progress	This bit indicates that PROGRAM EXECUTE, PAGE READ, BLOCK ERASE, RESET is in progress.
ECCS3 ECCS2 ECCS1 ECCS0	ECC Status	ECCS provides ECC status as follows: 0000b = No bit errors were detected during the previous read algorithm. 0001b = 1 bit error was detected and corrected. 0010b = 2 bit error was detected and corrected. 0011b = 3 bit error was detected and corrected. 0100b = 4 bit error was detected and corrected. 0101b = 5 bit error was detected and corrected. 0110b = 6 bit error was detected and corrected. 0111b = 7 bit error was detected and corrected. 1000b = bit error was detected and not corrected. 1100b = 8bit errors were detected and corrected, error bit number is going to exceed the tolerance. ECCSx is set to 0000b either following a RESET, or at the beginning of the READ. It is then updated after the device completes a valid READ operation. ECCS is invalid if internal ECC is disabled (via a SET FEATURES command to reset ECC_EN to 0). After power-on RESET, ECC status is set to reflect the contents of block 0, page 0. ECCS1/0 bits are only valid after a page read command (0x13)

8. OTP Region

The device offers a protected, One-Time Programmable NAND Flash memory area. Four full pages (2112 bytes per page) are available on the device, and the entire range is guaranteed to be good. Customers can use the OTP area any way they want, like programming serial numbers, or other data, for permanent storage. When delivered from factory, feature bit OTP_PRT is 0.

To access the OTP feature, the user must issue the SET FEATURES command, followed by feature address B0h. When the OTP is ready for access, pages 00h–03h can be programmed in sequential order. The PROGRAM LOAD (02H) and PROGRAM EXECUTE (10H) commands can be used to program the pages. Also, the PAGE READ (13H) command and READ FROM CACHE (03h/0Bh/3Bh/6Bh/BBh/EBh) commands can be used to read the OTP area. The data bits used in feature address B0h to enable OTP access are shown in the table below.

OTP Access

To access OTP, perform the following command sequence:

- Issue the SET FEATURES command (1Fh) to set OTP_EN
- Issue the PAGE PROGRAM (if OTP_EN=1) or PAGE READ command

It is important to note that after bits 6 and 7 on the OTP register are set by the user, the OTP area becomes read-only and no further programming is supported. For OTP states, see the following table.

OTP Protect

- Issue the SET FEATURES command (1FH) to set OTP_EN and OTP_PRT
- 06H (WRITE ENABLE)
- Issue the PROGRAM EXECUTE (10H) command.

Table 3 OTP States

OTP_PRT	OTP_EN	State
0	0	Normal Operation
0	1	Access OTP region
1	1	<ol style="list-style-type: none"> 1. When the device power on state OTP_PRT is 0, user can set feature bit OTP_PRT and OTP_EN to 1, then issue PROGRAM EXECUTE (10H) to lock OTP, and after that OTP_PRT will permanently remain 1. 2. When the device power on state OTP_PRT is 1, user can only read the OTP region data.

9. Error Management

This NAND Flash device is specified to have the minimum number of valid blocks (NVB) of the total available blocks per die shown in the table below. This means the devices may have blocks that are invalid when shipped from the factory. An invalid block is one that contains at least one page that has more bad bits than can be corrected by the minimum required ECC. Additional bad blocks may develop with use. However, the total number of available blocks will not fall below NVB during the endurance life of the product.

Although NAND Flash memory devices may contain bad blocks, they can be used reliably in systems that provide bad-block management and error-correction algorithms. This ensures data integrity.

Internal circuitry isolates each block from other blocks, so the presence of a bad block does not affect the operation of the rest of the NAND Flash array.

NAND Flash devices are shipped from the factory erased. The factory identifies invalid blocks before shipping by attempting to program the bad-block mark in one every location in the first page of each invalid block. It may not be possible to program every location in an invalid block with the bad-block mark. However, the first spare area location in each bad block is guaranteed to contain the bad-block mark. This method is compliant with ONFI factory defect mapping requirements. See the following table for the bad-block mark.

System software should initially check the first spare area location for non-FFh data on the first page of each block prior to performing any program or erase operations on the NAND Flash device. A bad-block table can then be created, enabling system software to map around these areas. Factory testing is performed under worst-case conditions. Because invalid blocks may be marginal, it may not be possible to recover the bad-block mapping if the block is erased.

Table 9. Error Management Details

Description	Requirement
Minimum number of valid blocks (NVB)	2008
Total available blocks per die	2048
First spare area location	Byte 2048
Bad-block mark	Non FFh

10. ECC Protection

The device offers data corruption protection by offering optional internal ECC. READs and PROGRAMs with internal ECC can be enabled or disabled by setting feature bit ECC_EN. ECC is enabled after device power up, so the default READ and PROGRAM commands operate with internal ECC in the “active” state.

To enable/disable ECC, perform the following command sequence:

- Issue the SET FEATURES command (1FH).
- Set the feature bit ECC_EN as you want:
 1. To enable ECC, Set ECC_EN to 1.
 2. To disable ECC, Clear ECC_EN to 0.

During a PROGRAM operation, the device calculates an ECC code for the 2K page in the cache register, before the page is written to the NAND Flash array.

During a READ operation, the page data is read from the array to the cache register, where the ECC code is calculated and compared with the ECC code value read from the array. If error bits are detected, the error is corrected in the cache register. Only corrected data is output on the I/O bus. The ECC status bit indicates whether or not the error correction was successful. The ECC Protection table below shows the ECC protection scheme used throughout a page.

With internal ECC, the user must accommodate the following:

- Spare area definitions provided in the ECC Protection table below.
- ECC can protect according main and spare areas. Writes to the ECC area are ignored.

Power on Read without internal ECC

The device will automatically read first page of first block to cache after power on, then host can directly read data from cache for easy boot. However, the data is not promised correctly with ECC disabled.

Table 10 ECC Protection and Spare Area

Min Byte Address	Max Byte Address	ECC Protected	Number of Bytes	Area/Group	Description
000H	1FFH	Yes	512	Main 0 , Group A	User Data 0
200H	3FFH	Yes	512	Main 1 , Group B	User Data 1
400H	5FFH	Yes	512	Main 2 , Group C	User Data 2
600H	7FFH	Yes	512	Main 3 , Group D	User Data 3
800H	807H	No	8	Spare 4 , Group E	This Area is not covered by internal ECC, 800H is reserved for bad block mark
808H	82FH	Yes	40	Spare 5 , Group F	User Meta Data Area covered by internal ECC.
830H	83FH	No	16	Spare 6 , Group G	ECC_EN=1: this area contains Internal ECC Data, Read-Only, Programming to this area will be ignored ECC_EN=0: this area is writable for user

Data of same area/group must be programmed for only once when internal ECC is enabled.
Multi-Programming to the same group will corrupt internal ECC data.
Data of different area/group can be programmed separately.

11. Electrical Characteristics

11.1. Absolute Maximum Ratings

Operating Temperature	-30°C to +85°C
Storage Temperature	-40°C to +125°C
Voltage on I/O Pin with Respect to Ground	-0.3V to 3.6V
V _{CC}	-0.3V to 3.6V

***NOTICE:** Stresses beyond those listed under “Absolute Maximum Ratings” may cause permanent damage to the device. This is a stress rating only and functional operation of the device at these or any other conditions beyond those indicated in the operational sections of this specification are not implied. Exposure to absolute maximum rating conditions for extended periods may affect device reliability.

11.2. Pin Capacitance

Applicable over recommended operating range from T_A = 25°C, f = 1 MHz.

Symbol	Test Condition	Max	Units	Conditions
C	Input Capacitance	6	pF	V _{IN} = 0V
C ⁽¹⁾ OUT	Output Capacitance	8	pF	V _{OUT} = 0V

Note: 1. Characterized and is not 100% tested.

11.3. Power-up and Power Down Timing

Do not turn off the power before write/erase operation is complete. Avoid using the device when the battery is low. Power shortage and/or power failure before write/erase operation is complete will cause loss of data and/or damage to data.

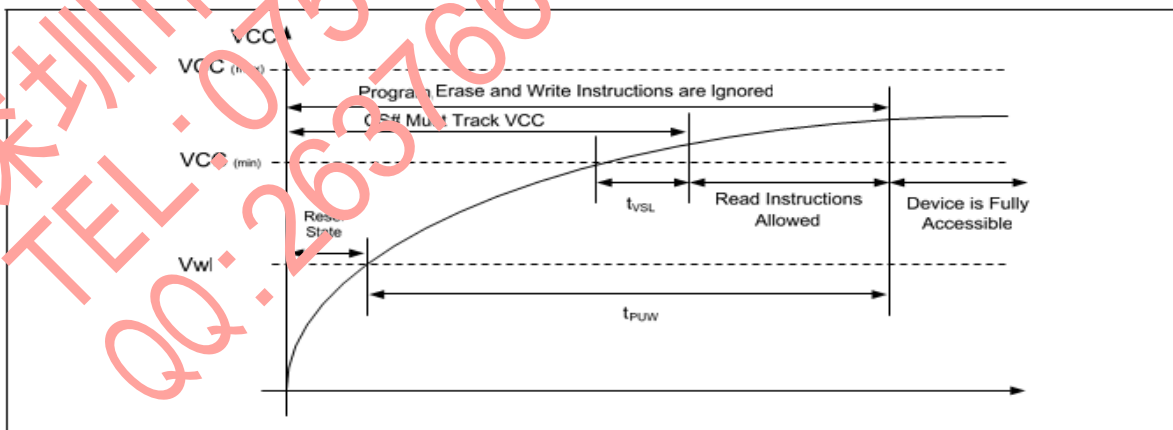

Figure 32 Power-On Timing

Table 11 Power-On Timing and Write Inhibit Threshold

PARAMETER	SYMBOL	SPEC		UNIT
		MIN	MAX	
VCC (min) to CS# Low	t_{VSL}	1		ms
Time Delay Before Write Instruction	t_{PUW}	6		ms
Write Inhibit Voltage	VWI		2.5	V

深圳市义嘉泰科技有限公司
TEL: 0755-89486115
QQ: 2637667358

11.4. DC Electrical Characteristics

Table 12 DC Characteristics

Applicable over recommended operating range from: TA = -30°C to 85°C, VCC = 2.7V to 3.6V, (unless otherwise noted)

I _{cc2}	Opera
V _{IL} (1)	Input
V _{IH}	Input
V _{OL}	Output
V _{OH}	Output

Notes: 1. V_{IL} min and V_{IH} max are reference only and are not tested.

11.5 AC Measurement Conditions

Table 13 AC Measurement Conditions

SYMBOL	PARAMETER	SPEC		UNIT
		MIN	MAX	
CL	Load Capacitance		40	pF
	Signal Line inductance		16	nH
TR, TF	Input Rise and Fall Times		5	ns
V _{IN}	Input Pulse Voltages	0.2 V _{CC} to 0.8 V _{CC}		V
I _N	Input Timing Reference Voltages	0.3 V _{CC} to 0.7 V _{CC}		V
O _{UT}	Output Timing Reference Voltages	0.5V _{CC}		V

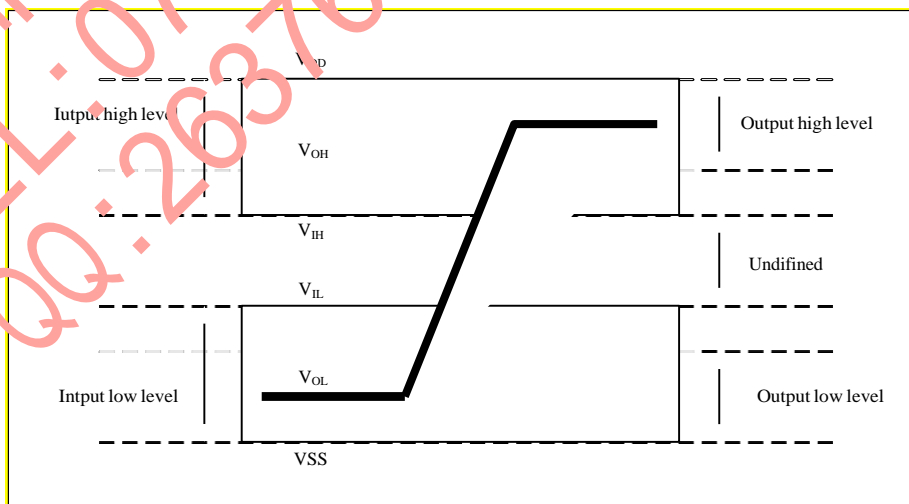

Figure 33 Bus Signal Level

11.6. AC Electrical Characteristics

Table 14 AC Characteristics

Applicable over recommended operating range from: TA = -30°C to 85°C, VCC = 2.7V to 3.6V

SYMBOL	PARAMETER	SPEC			UNIT
		MIN	TYP	MAX	
F _C	Serial Clock Frequency for: all command			90	MHz
t _{CH1} (1)	Serial Clock High Time	5.5			ns
t _{CL1} (1)	Serial Clock Low Time	5.5			ns
t _{CHCH} (2)	Serial Clock Rise Time (Slew Rate)	0.1			V/ns
t _{CHCL} (2)	Serial Clock Fall Time (Slew Rate)	0.1			V/ns
t _{SLCH}	CS# Active Setup Time	5			ns
t _{CHSH}	CS# Active Hold Time	5			ns
t _{SHCH}	CS# Not Active Setup Time	5			ns
t _{CHSL}	CS# Not Active Hold Time	5			ns
t _{SHSL} /t _{Cs}	CS# High Time	20			ns
t _{SHQZ} (2)	Output Disable Time			10	ns
t _{CLQX}	Output Hold Time	0			ns
t _{DVCH}	Data In Setup Time	2			ns
t _{CHDX}	Data In Hold Time	3			ns
t _{HLCH}	HOLD# Low Setup Time (relative to CLK)	5			ns
t _{HHCH}	HOLD# High Setup Time (relative to CLK)	5			ns
t _{CHHH}	HOLD# Low Hold Time (relative to CLK)	5			ns
t _{CHHL}	HOLD# High Hold Time (relative to CLK)	5			ns
t _{THLQZ} (2)	HOLD# Low to High Z Output			15	ns
t _{HHQ} ⁽²⁾	HOLD# High to Low Z Output			15	ns
t _{CLQV}	Output Valid from CLK			8	ns
t _{WHSL}	WP# Setup Time before CS# Low	20			ns
t _{SHWL}	WP# Hold Time after CS# High	100			ns
t _{IO_skew}	First IC to last IC data valid time			600	ps

- Notes: 1. t_{CH1}+t_{CL1}>= 1/(F_C)
 2. Characterized and not 100% tested

Table 15 Performance Timing

SYMBOL	PARAMETER	SPEC			UNIT
		MIN	TYP	MAX	
t _{RST}	CS# High to Next Command After Reset(FFh)			500	μS
t _{RD}	Page Read From Array (with ECC)		260	400	μS
	Page Read From Array (without ECC)		240	300	
t _{PROG}	Page Program (without ECC)		250	500	μS
	Page Program (wit ECC)		350	700	
t _{ERS}	Block Erase		3	10	ms

Note: If there is no operation with the chip in five seconds, the chip will enter into sleep state. As operation again will need the chip to awake firstly, the time of Page Read, Page Program and Block erase will be increased by an additional 3ms or so.

12. SPI Serial Timing

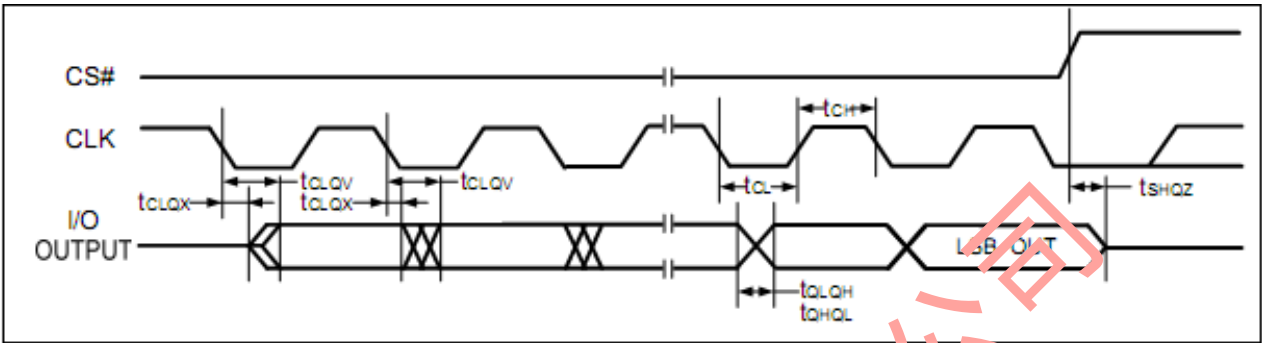

Figure 34 Serial Output Timing



Figure 35 Serial Input Timing

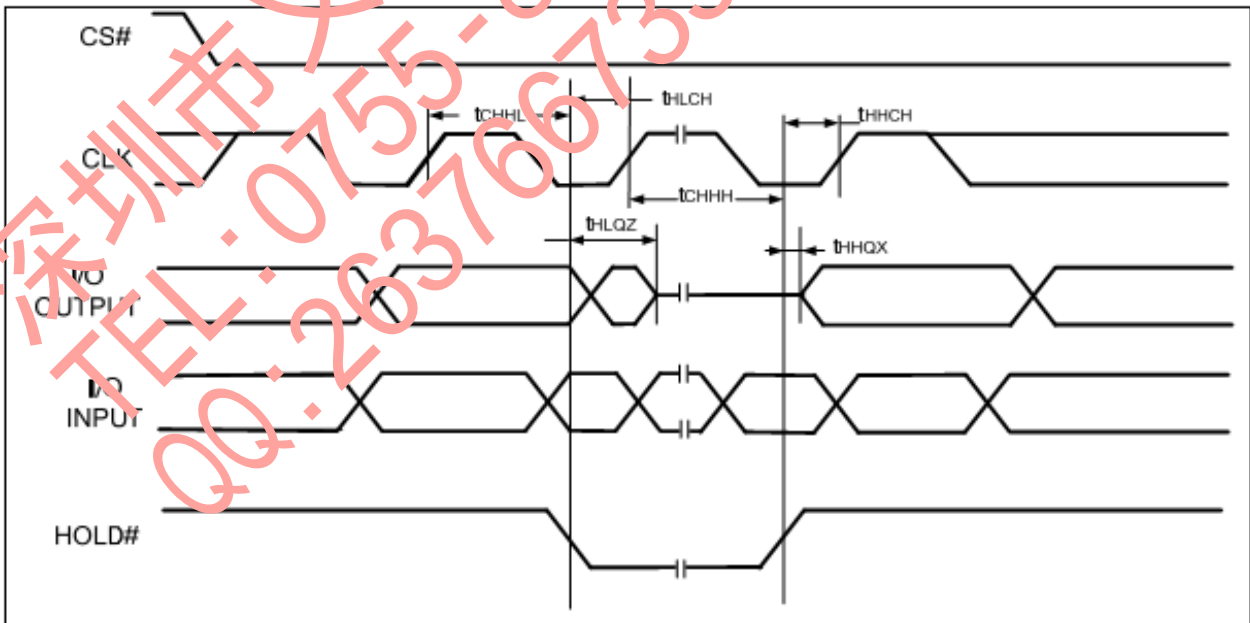
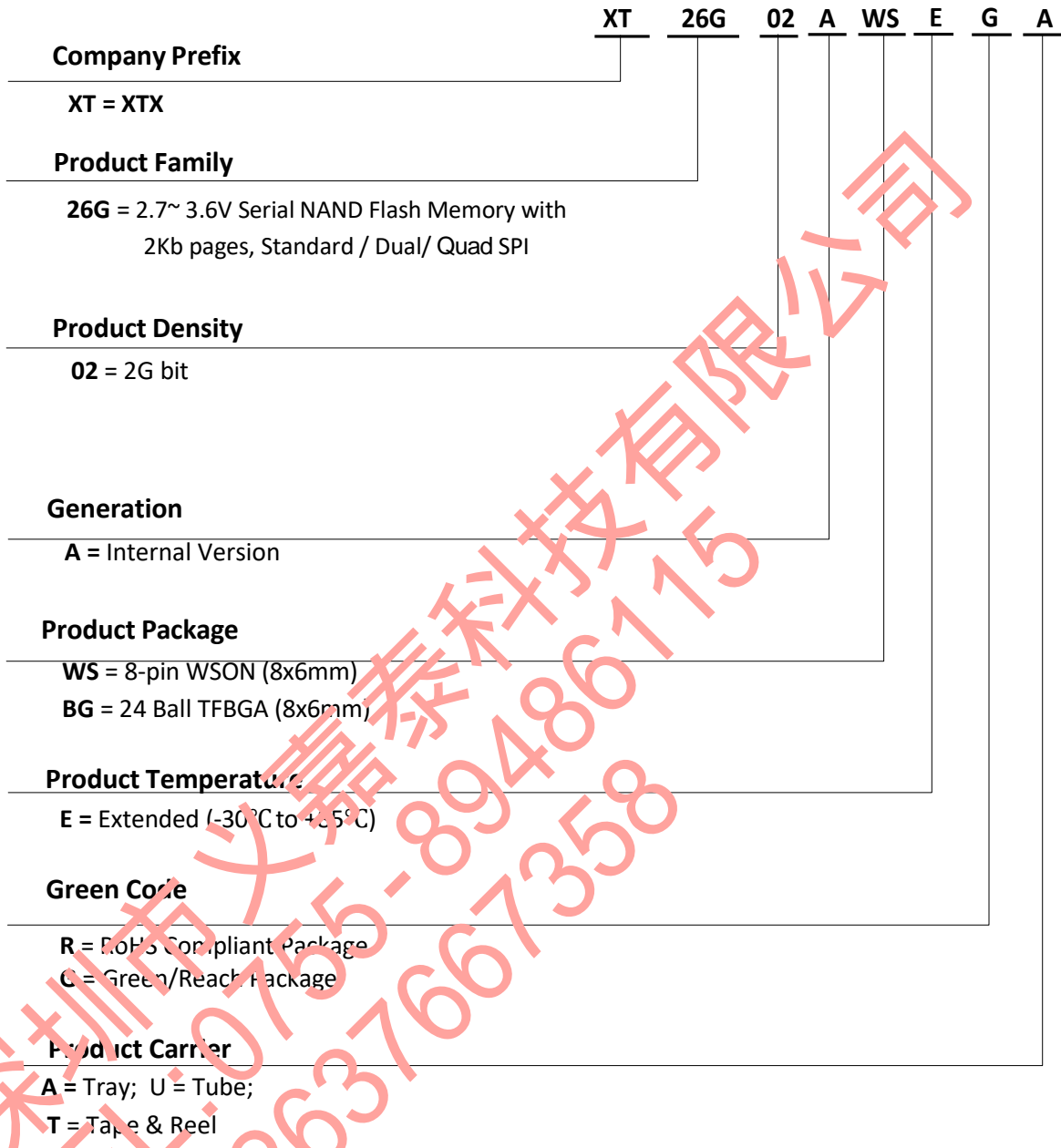

Figure 36 Hold Timing

13. ORDERING INFORMATION



深圳兴文嘉泰科技有限公司
 TEL: 0755-89486115
 QQ: 2637667358

14. PACKAGE INFORMATION

14.1. 8-Pad WSON8 (8*6mm)

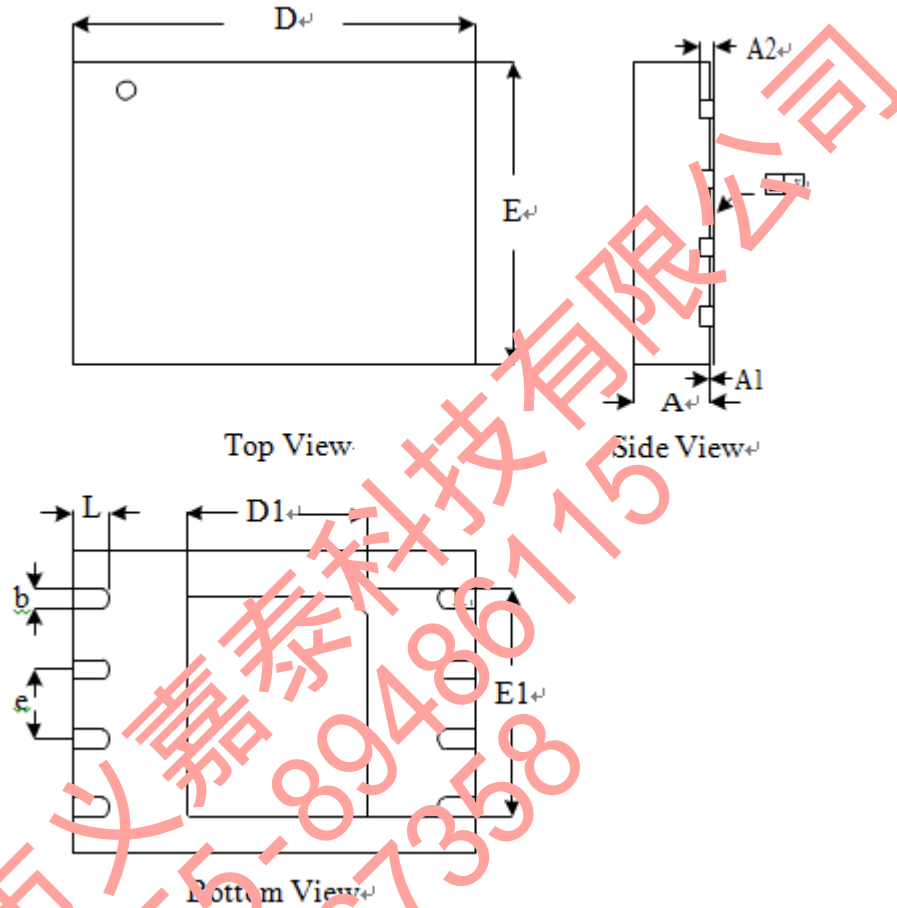

Dimensions

Symbol	Unit										
	A	A1	A2	b	D	D1	E	E1	e	y	L
mm	Min	0.75		0.35	7.90	3.25	5.90	4.15		0.00	0.40
	Nom	0.75	0.20	0.40	8.00	3.40	6.00	4.30	1.27		0.50
	Max	0.80	0.05		0.45	8.10	3.50	6.10	4.40		0.05
Inch	Min	0.029		0.014	0.311	0.128	0.232	0.163		0.00	0.016
	Nom	0.030	0.008	0.016	0.315	0.134	0.236	0.169	0.05		0.020
	Max	0.032	0.002		0.019	0.319	0.138	0.240	0.173	0.002	0.024

14.2. 24-Ball TFBGA (8*6mm)

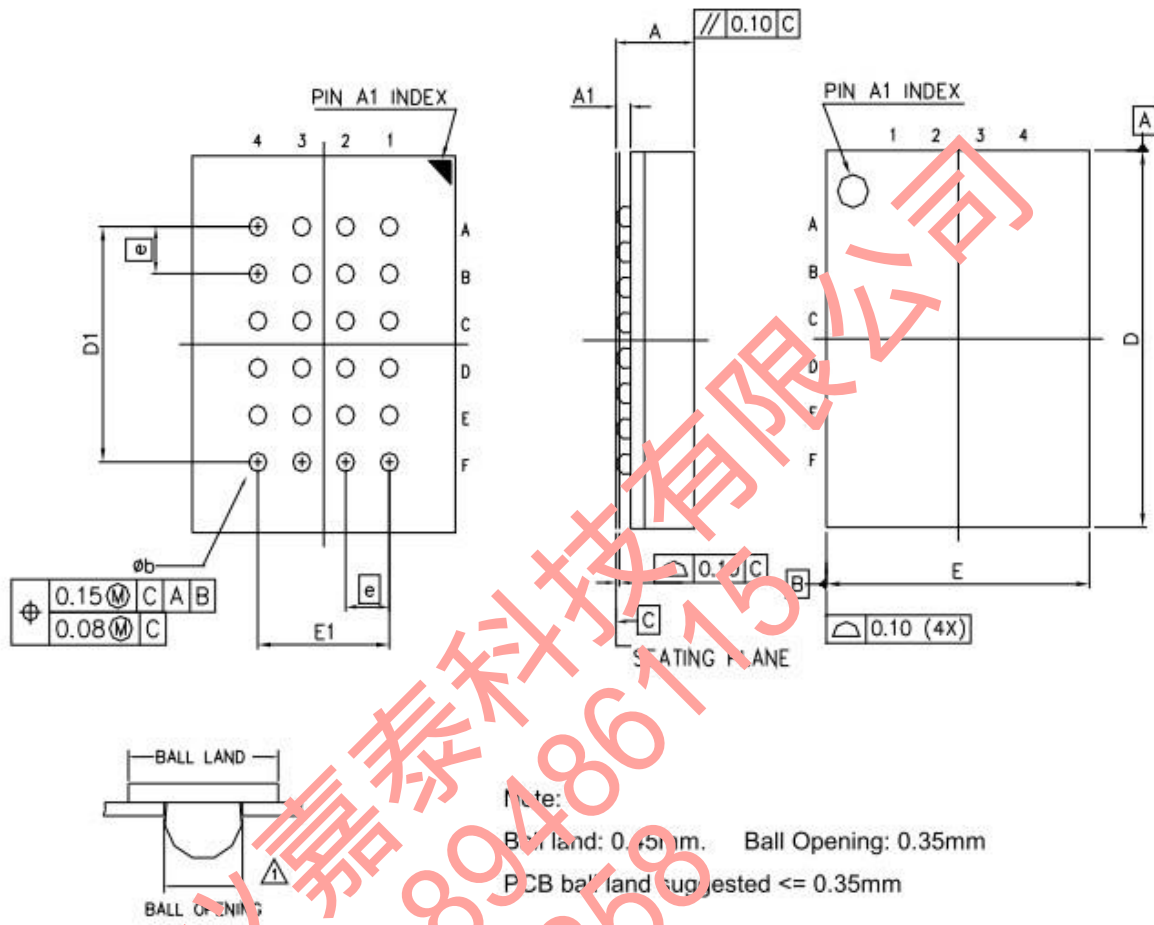

Symbol	Millimeters			Inches		
	Min	Nom	Max	Min	Nom	Max
A	---	---	1.20	---	---	0.047
A1	0.25	0.30	0.35	0.010	0.012	0.014
b	0.5	0.40	0.45	0.014	0.016	0.018
D	7.95	8.00	8.05	0.313	0.315	0.317
D1		5.00 BSC			0.197 BSC	
E	5.95	6.00	6.05	0.234	0.236	0.238
E1		3.00 BSC			0.118 BSC	
e		1.00 BSC			0.039 BSC	

15. REVISION HISTORY

Revision	Description	Date
0.0	Initial Release	Nov-8-2017
0.1	Revise table #2 Features setting; Table #7 Status Register Bit description	Nov-29-2017
0.2	Revise page #16, 17 section 7.6.5 & 7.6.7 & package carrier typo error.	Dec-06-2017
0.3	Revise typo error ("eight" to "four" full page) at section #9 OTP Page #25	Jan-26-2018
0.4	Revise extended temperature range from -25c-85c to -30c-85c.	Jul-19-2018
0.5	Revise ECC layout in Page #30	Sep-25-2018
0.6	Add the note of hold pin	Mar-23-2019
0.7	Correct the unclear description	Dec-5-2019
0.8	Add the note of Table 15 Performance Timing	Mar-27-2020



深圳市义嘉泰科技有限公司
EBESTER COMPANY LIMITED

Tel: (86 755) 89486115
Fax: (86 755) 83749019

Web Site: www.szgsensor.com

* Information furnished is believed to be accurate and reliable. However, XTX Technology Limited assumes no responsibility for the consequences of use of such information or for any infringement of patents or other rights of third parties which may result from its use. No license is granted by implication or otherwise under any patent rights of XTX Technology Limited. Specifications mentioned in this publication are subject to change without notice. This publication supersedes and replaces all information previously supplied. XTX Technology Limited products are not authorized for use as critical components in life support devices or systems without express written approval of